



TOMASEFFA

COMPLEMENTI
DESIGN COLLECTION

COMPLEMENTI

DESIGN COLLECTION

indice / contents	2
tavoli / tables	8
sedie / chairs	64
madie / sideboards	88
poltrone e pouf / armchairs and poufs	168
tavolini / coffee tables	202
specchi / mirrors	236
accessori / accessories	250
wallpaper	320
pagine tecniche / technical pages	330
pagine di sintesi / summary	337

tavoli / tables



plinto p. 10



avalon p. 14



tudor p. 24



brigitte p. 32



bloom p. 40



doppio passo p. 48



infinity p. 56

sedie/ chairs



york p. 66



lolita p. 68



lola p. 72



bea p. 74



time p. 76



betty p. 78



skinny p. 80



tiffany p. 82



tiffany gonna p. 86

madie / sideboards



sir p. 90



regolo p. 98



remix p. 108



metropolis p. 116



diagonal p. 134



athena p. 150



madison p. 160



atlante p. 164

poltrone & pouf / armchairs & ottomans



loft p. 170



flower p. 176



soft p. 180



maya p. 184



vanessa p. 188



linda p. 190



cookie p. 192



giglio p. 196



guccino p. 198



comodo p. 200

tavolini / coffee and side tables



joy p. 204



joy decor p. 208



joy wood p. 210



caruso p. 212



eclisse p. 214



brigitte p. 216



strike p. 222



bloom p. 226



flexo p. 230

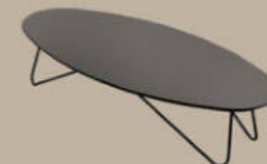

senzatempo p. 232



33 p. 234

specchi / mirrors



bolle p.238 inside p.240 hashtag p.242 vip p.246 dolcevita p.248

accessori / accessories



kalista p.252 kalista midi p.254 kalista fianco p.255 movida p.256



raster p.260 ring p.264 ciko p.266 petalo p.270



scrittoio p.272 panketta p.278 tasca p.282 toilette replay p.284

accessori / accessories



shape p.286 ingressi p.292 up&down p.294 orologi p.296



lettering p.298



quadri p.300



tappeti p.311



plaid p.317



cuscini p.318



wallpaper p.320

tavoli

tables

Trascorrere del tempo in famiglia o con gli amici a tavola è un'abitudine da apprezzare e coltivare. Protagonista della convivialità, scegliere il tavolo giusto è il primo passo per portare nel living il piacere di stare insieme.

Spending time around the table with family and friends is a treat best served regularly! Finding the right table - the centrepiece of the gathering - is the first step towards bringing the joy of entertaining and family time into your living spaces.



PLINTO



◀ Pagina precedente
 Tavolo Plinto piano vetro trasparente 320, struttura legno rovere termocotto e metallo antracite 160.
 L 240 P 110 H 75 cm
 Sedie York struttura legno rovere termocotto, rivestimento cat.b econabuk 12.
 L 47 P 61 H 92/48 cm
 Sedia Lola struttura legno rovere termocotto, rivestimento cat.c lino froissè 123.
 L 55 P 53 H 81/47 cm
 Madia sospesa Sir S02 struttura laccato opaco salvia 159 e legno rovere termocotto.
 L 270 P 40 H 54 cm

Preceding page
 Plinto table with transparent 320 glass top, heat-treated oak wood and anthracite 160 metal frame.
 L 240 W 110 H 75 cm
 York chairs with a heat-treated oak wood frame upholstered with cat. b eco-nubuck 12.
 W 47 D 61 H 92/48 cm
 Lola chair with heat-treated oak frame upholstered with cat. c froissè linen 123 fabric.
 W 55 D 53 H 81/47 cm
 Wall-hung Sir S02 sideboard with a matt sage 159 lacquered carcass and heat-treated oak wood.
 W 270 D 40 H 54 cm

PLINTO

misure / size L/W200 P/D 100 H 75 cm L/W240 P/D 110 H 75 cm

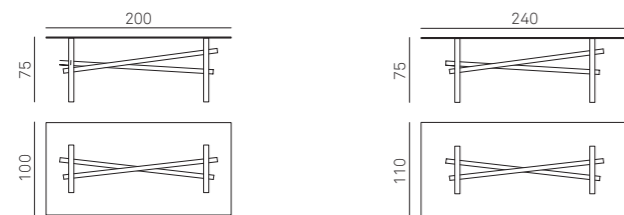

FINITURE PIANO / TOP FINISHES

VETRO / GLASS



320
 Vetro Trasparente
 Transparent glass

FINITURE GAMBE / LEG FINISHES

ESSENZE / WOOD FINISHES



LGN-FO
 Frassino Oriente
 Eastern Ash



LGN-RT
 Rovere termocotto
 Heat-treated Oak

LEGNO NATURALE / NATURAL WOOD



Rovere Nodato naturale
 Natural knotted oak

LACCATI / LACQUERS

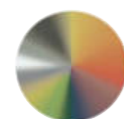

colori laccati opachi a campionario
(vedi pagina 333)
 choice of matt lacquer colours
 from our range (see page 333)

FINITURE CILINDRI / CYLINDERS FINISHES

METALLO / METAL



Antracite 160
 Anthracite 160

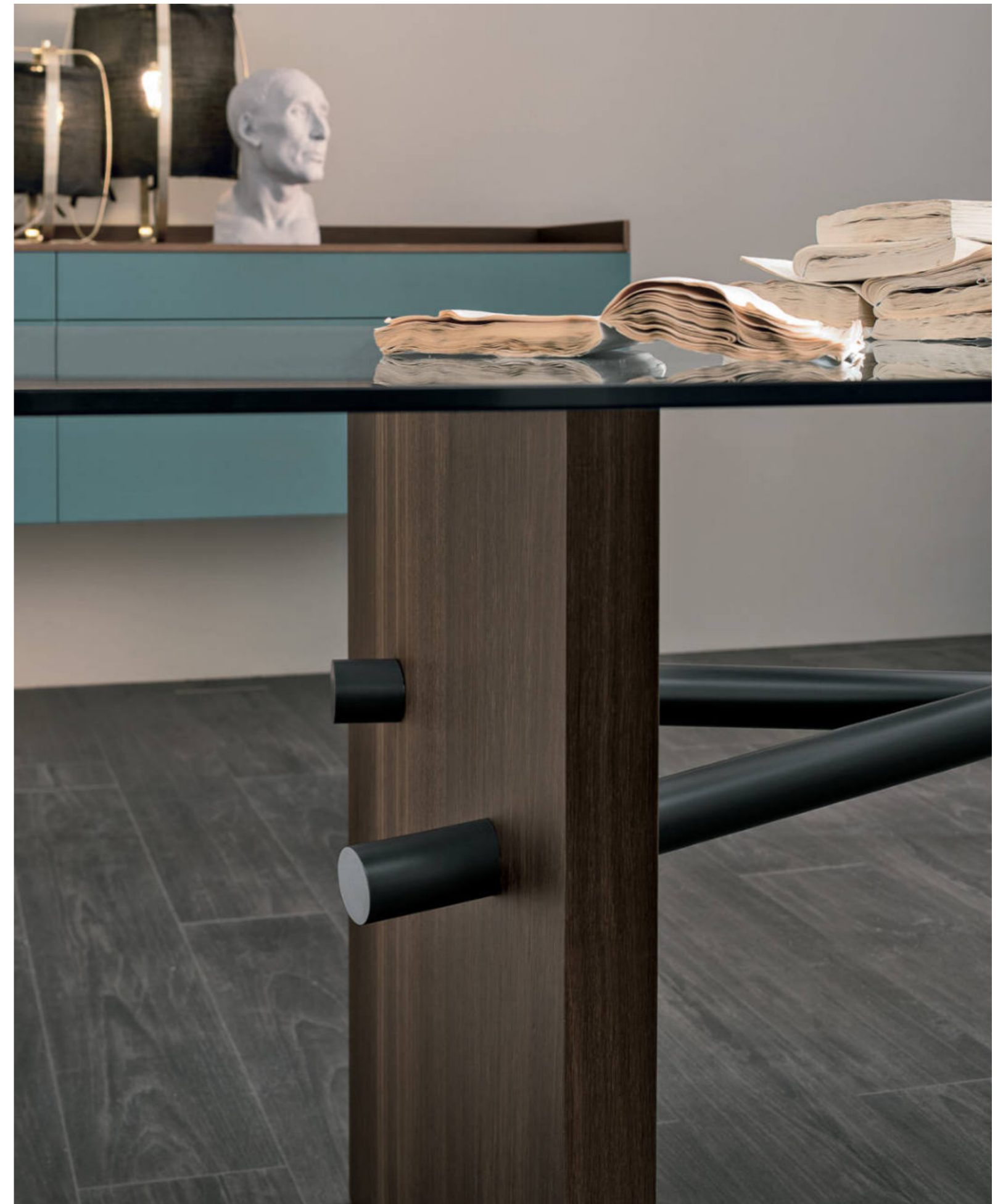

AVALON





< **Pagina precedente**
 Tavolo Avalon piano Hpl 12, struttura legno
 laccato poro aperto antracite 260.
 L 240 P 120 H 75 cm
 Sedie Betty cat. b ecopelle extrema 16.
 L 45 P 54 H 81/46 cm
 Madie Regolo R03 struttura materico opaco
 bianco gesso, inserto maniglia materico opaco
 antracite e metallo antracite 160.
 L 108 P 40 H 147,5 cm
 Tappeto Gradient.

Preceding page
 Avalon table with an HPL 12 top and an open-
 pore anthracite 260 lacquered wood frame.
 L 240 W 120 H 75 cm
 Betty chairs upholstered with cat. b extrema
 16 eco-leather.
 W 45 D 54 H 81/46 cm
 Regolo R03 sideboards with a textured
 matt chalk white carcass and textured matt
 anthracite and anthracite 160 metal handle
 insert.
 W 108 D 40 H 147.5 cm
 Gradient rug.



Tavolo Avalon piano Hpl 11, struttura legno laccato poro aperto antracite 260.
L 240 P 120 H 75 cm

Sedie Bea struttura legno rovere termocotto.
L 42 P 53 H 78/44 cm

Contenitori sospesi Atlante laccato opaco antracite 160.
L 288 P 40 H 37,4 cm

Tappeto Black & White.

Wallpaper WPT 553.

Avalon table with an HPL 11 top and an open-pore anthracite 260 lacquered wood frame.
L 240 W 120 H 75 cm

Bea chairs with a heat-treated oak wood frame.
W 42 D 53 H 78/44 cm

Wall-hung Atlante units in matt anthracite 160 lacquer.
W 288 D 40 H 37.4 cm

Black & White rug.

WPT 553 wallpaper.

AVALON

Tavolo Avalon piano materico cemento chiaro, struttura legno laccato poro aperto antracite 260.
L 240 P 120 H 76,8 cm

Sedie York struttura legno laccato poro aperto antracite 260, rivestimento cat. b ecopelle vintage 101.
L 47 P 61 H 92/48 cm

Avalon table with a light textured cement top and an open-pore anthracite 260 lacquered wood frame.
L 240 W 120 H 76,8 cm

York chairs with an open-pore anthracite 260 lacquered wood frame upholstered with cat. b vintage 101 eco-leather.
W 47 D 61 H 92/48 cm

AVALON

misure / size

L/W 180 P/D 100 H 75 cm
L/W 200 P/D 110 H 75 cm
L/W 240 P/D 120 H 75 cm

misure al centimetro / custom-sized

L/W 180 ÷ 240 cm solo con piano materico laccato opaco e poro aperto
P/D 100 ÷ 120 cm only for textured top matt lacquered and open pore

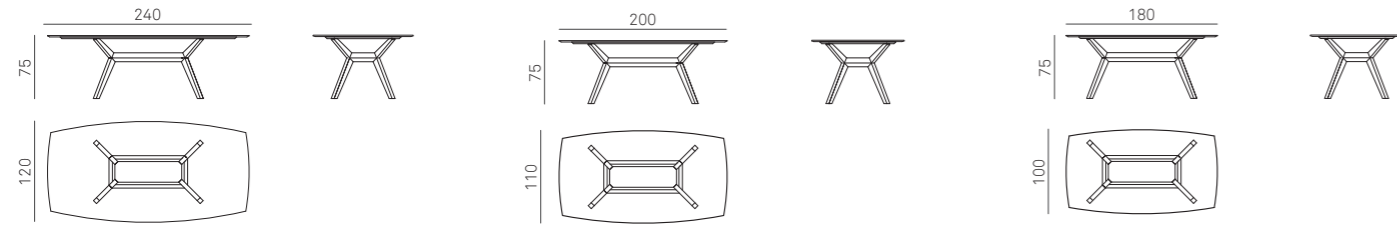

FINITURE PIANO / TOP FINISHES

MATERICO ESSENZA / TEXTURED WOOD



MT-FO
Frassino Oriente
Eastern Ash



MT-RT
Rovere termocotto
Heat-treated Oak

MATERICO NODATO / KNOTTED TEXTURED



MT-RNC
Nodato chiaro
Light Knotted

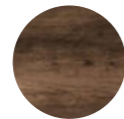

MT-RNS
Nodato scuro
Dark knotted

MATERICO / TEXTURED



MT-CC
Cemento chiaro
Light cement



MT-CS
Cemento scuro
Dark cement

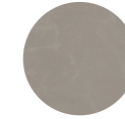

MT-CV
Cemento Cava
Cava cement

HPL

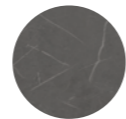

HPL
11



HPL
12

LEGNO LACCATO PORO APERTO / OPEN-PORE LACQUERED WOOD



221 PA
Bianco Gesso
Chalk white



222 PA
Panna
Cream



224 PA
Madreperla
Mother of pearl



227 PA
Hot
Hot grey

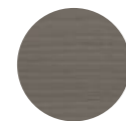

230 PA
Grigio Piacenza
Piacenza grey



250 PA
Canapa
Hemp

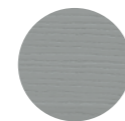

252 PA
Pomice
Pumice

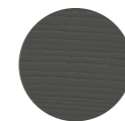

260 PA
Antracite
Anthracite

LACCATI / LACQUERS

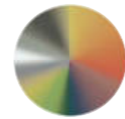

colori laccati opachi a campionario
(vedi pagina 333)
choice of matt lacquer colours
from our range (see page 333)

FINITURE STRUTTURA / BASE FINISHES

LEGNO LACCATO PORO APERTO / OPEN PORE LACQUERED WOOD

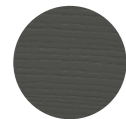

260 PA
Antracite
Anthracite



TUDOR



TUDOR ALLUNGABILE

Tavolo Tudor chiuso / Shut Tudor table



Tavolo Tudor con una allunga / Tudor table with one extension



Tavolo Tudor con due allunghe / Tudor table with two extensions



← **Pagina precedente**
Tavolo Tudor piano rovere naturale scortecciato, struttura metallo antracite 160 e metallo bianco gesso 121.
L 350 P 110 H 74 cm
Sedie Betty cat. b ecopelle vintage 1009.
L 45 P 54 H 81/46 cm
Tappeto Dots.

Preceding page
Tudor table with a stripped natural oak top and an anthracite 160 metal and chalk white 121 metal frame.
L 350 W 110 H 74 cm
Betty chairs upholstered with cat. b vintage 1009 eco-leather.
W 45 D 54 H 81/46 cm
Dots rug.





TUDOR

Tavolo Tudor piano legno rovere naturale scortecciato, struttura metallo antracite 160 e metallo bordeaux 156.
L 350 P 110 H 74 cm

Sedie Tiffany Gonna cat. c lino froissé 019.
L 46 P 50 H 83/47 cm

Wallpaper WPT 553.

Tudor table with a stripped natural oak wood top and an anthracite 160 metal and burgundy 156 metal frame.
L 350 W 110 H 74 cm

Tiffany Gonna chairs in cat. c froissé linen 019 fabric.
W 46 D 50 H 83/47 cm

WPT 553 wallpaper.



Variante con basamento in vetro.
Version with glass base.



TUDOR

misure / size **tudor fisso / fixed**

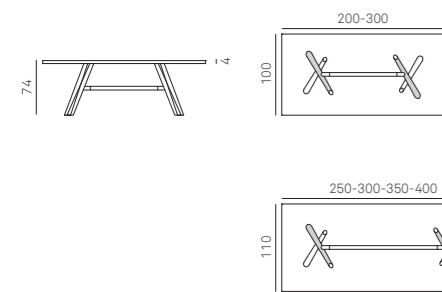

tudor allungabile / extending

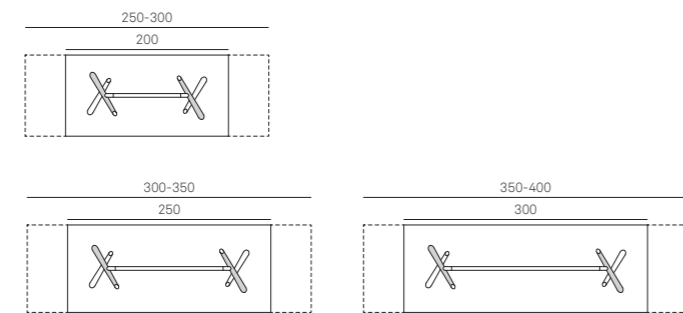

FINITURE TOP / TOP FINISHES

ESSENZE / WOOD FINISHES

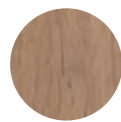

Rovere naturale
scortecciato
Stripped natural oak

FINITURE STRUTTURA / BASE FINISHES

DI SERIE FINITURA ANTRACITE CON PARTICOLARE GAMBA PERSONALIZZABILE IN COLORE LACCATO OPACO
ANTHRACITE FINISH AS STANDARD WITH LEG DETAIL IN YOUR CHOICE OF MATT LACQUERED FINISH



Antracite 160
Anthracite 160

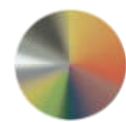

Gamba personalizzabile colori laccati opachi a
campionario (vedi pagina 333)
Customisable leg choice of matt lacquer colours
from our range (see page 333)

BRIGITTE



Tavolo Brigitte piano materico nodato scuro, struttura metallo antracite 160. Ø 120 H 75 cm.

Sedia Betty cat. 1/one atom 10. L 45 P 54 H 81/46 cm.

Libreria Movida struttura metallo antracite 160, ripiani materico nodato scuro. L 74 P 38 H 190 cm.

Brigitte table with textured dark knotted top and anthracite 160 metal frame. Ø 120 H 75 cm.

Betty chair upholstered with cat. 1/one atom 10. W 45 D 54 H 81/46 cm.

Movida bookcase with anthracite 160 metal frame and textured dark knotted shelves. W 74 D 38 H 190 cm.



BRIGITTE

Tavolo Brigitte piano laccato opaco zafferano 158, struttura metallo zafferano 158.
Ø 120 H 75 cm

Sedia Tiffany Gonna cat.c lino froissé 019.
L 46 P 50 H 83/47 cm

Madia Madison laccato opaco antracite 160.
L 207 P 49 H 76 cm

Tavolino 33 versione 12.
Ø 40 H 38 cm

Brigitte table with a matt saffron 158
lacquered top and a saffron 158 metal frame.
Ø 120 H 75 cm

Tiffany Gonna chair in cat. c froissé linen 019
fabric.
W 46 D 50 H 83/47 cm

Matt anthracite 160 lacquered Madison
sideboard.
W 207 D 49 H 76 cm

33 coffee table, version 12.
Ø 40 H 38 cm

BRIGITTE



Piano laccato opaco bordeaux 156, struttura metallo bordeaux 156. Matt burgundy 156 lacquered top, burgundy 156 metal frame.



Piano laccato opaco carta da zucchero 155, struttura metallo carta da zucchero 155. Matt blue grey 155 lacquered top, blue grey 155 metal frame.



Piano grafica 360, struttura metallo salvia 159. Graphic 360 top, sage 159 metal frame.



Piano laccato opaco smoke 128, struttura peltro. Matt smoke 128 lacquered top, pewter frame.



Piano materico nodato chiaro, struttura metallo bianco gesso 121. Textured light knotted top, chalk white 121 metal frame.



Piano grafica 331, struttura metallo bianco gesso 121. Graphic 331 top, chalk white 121 metal frame.

BRIGITTE

Tavolo Brigitte piano grafica 350, struttura metallo antracite 160. Ø 120 H 75 cm

Sedie Tiffany Gonna cat.c lino froissè 100. L 46 P 50 H 83/47 cm

Tappeto Black & White.

Brigitte table with graphic 350 top and anthracite 160 metal frame. Ø 120 H 75 cm

Tiffany Gonna chairs in cat. c froissè linen 100 fabric. W 46 D 50 H 83/47 cm

Black & White rug.



BRIGITTE

misure / size Ø 120 H 75 cm

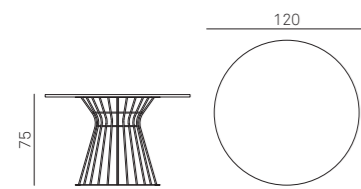

FINITURE PIANO / TOP FINISHES

MATERICO NODATO / KNOTTED TEXTURED



MT-RNC
Nodato chiaro
Light Knotted

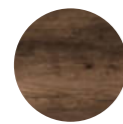

MT-RNS
Nodato scuro
Dark knotted

MATERICO ESSENZA / TEXTURED WOOD



MT-FO
Frassino Oriente
Eastern Ash



MT-RT
Rovere termocotto
Heat-treated Oak

MATERICO / TEXTURED



MT-CC
Cemento chiaro
Light cement



MT-CS
Cemento scuro
Dark cement

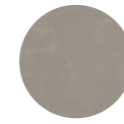

MT-CV
Cemento Cava
Cava cement

LEGNO LACCATO PORO APERTO / OPEN-PORE LACQUERED WOOD



221 PA
Bianco Gesso
Chalk white



222 PA
Panna
Cream



224 PA
Madreperla
Mother of pearl



227 PA
Hot
Hot grey



230 PA
Grigio Piacenza
Piacenza grey



250 PA
Canapa
Hemp

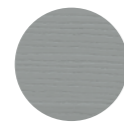

252 PA
Pomice
Pumice

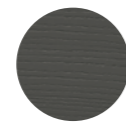

260 PA
Antracite
Anthracite

LACCATI / LACQUERS

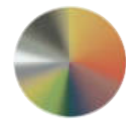

colori laccati
opachi e lucidi a
campionario
(vedi pagina 333)
choice of matt
and glossy
lacquer colours
from our range
(see page 333)

GRAFICHE PIANO / TOP GRAPHIC DESIGNS

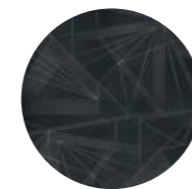

302

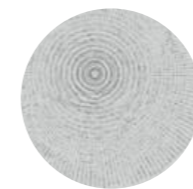

303

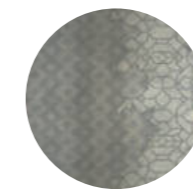

305

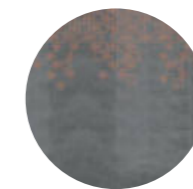

306

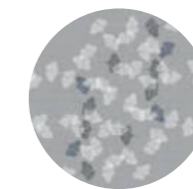

307

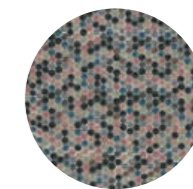

309

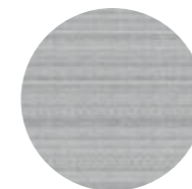

311

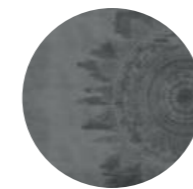

312

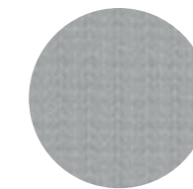

313

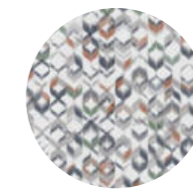

315

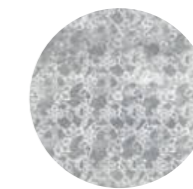

316

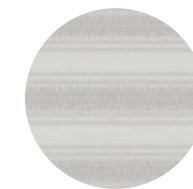

330

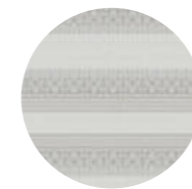

331

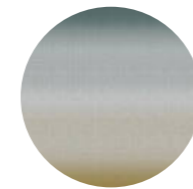

335

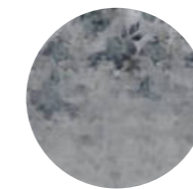

350

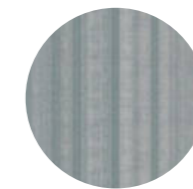

360

BLOOM

Tavolo Bloom struttura legno rovere termocotto, inserto rame.
L 220 P 110 H 75 cm

Sedie York struttura legno rovere termocotto, rivestimento cat. b ecopelle vintage 107.
L 47 P 61 H 92/48 cm

Madia Athena 3 ante struttura laccato opaco pomice 152, inserto vetro antracite 360.
L 181 P 51 H 85 cm

Bloom table with heat-treated oak frame and copper insert.
W 220 D 110 H 75 cm

York chairs with a heat-treated oak wood frame upholstered with cat. b vintage 107 eco-leather.
W 47 D 61 H 92/48 cm

3-door Athena sideboard with a matt pumice 152 lacquered carcass and anthracite 360 glass insert.
W 181 D 51 H 85 cm



BLOOM

Tavolo Bloom struttura legno rovere termocotto, inserto rame.
L 150 P 150 H 75 cm

Sedie York struttura legno rovere termocotto, rivestimento cat. b ecopelle vintage 1011.
L 47 P 61 H 92/48 cm

Tappeto Gradient.

Bloom table with a heat-treated oak frame and copper insert.
L 150 W 150 H 75 cm

York chairs with a heat-treated oak wood frame upholstered with cat. b vintage 1011 eco-leather.
W 47 D 61 H 92/48 cm

Gradient rug.





BLOOM

Tavolo Bloom piano gres 02, struttura legno rovere termocotto.
L 220 P 110 H 75 cm

Sedia Lolita struttura legno rovere termocotto, rivestimento cat.b hugo 04.
L 51 P 56 H 79/47 cm

Sedia Lolita struttura legno rovere termocotto, rivestimento cat.b ecopelle vintage 102.
L 51 P 56 H 79/47 cm

Sedia Lola struttura legno rovere termocotto, rivestimento cat.b ecopelle extrema 12.
L 55 P 53 H 81/47 cm

Tappeto Frame.

Bloom table with a stoneware 02 top and a heat-treated oak wood frame.
L 220 W 110 H 75 cm

Lolita chair with a heat-treated oak wood frame upholstered with cat. b hugo 04.
W 51 D 56 H 79/47 cm

Lolita chair with a heat-treated oak wood frame upholstered with cat. b vintage 102 eco-leather.
W 51 D 56 H 79/47 cm

Lola chair with a heat-treated oak wood frame upholstered with cat. b extrema 12 eco-leather.
W 55 D 53 H 81/47 cm

Frame rug.

BLOOM

misure / size L/W 220 P/D 110 H 75 cm L/W 150 P/D 150 H 75 cm



FINITURE TOP E BASE / BASE AND TOP FINISHES

ESSENZE / WOOD FINISHES



LGN-RT
Rovere Termocotto
Heat-treated Oak

GRES PORCELLANATO / PORCELAIN STONEWARE



Gres 01
Gres 01 stoneware



Gres 02
Gres 02 stoneware

FINITURA INSERTO / INSERT FINISHES

INSERTO / INSERT



Rame
Copper

Non disponibile per piano in gres.
Not available for Gres stoneware top.

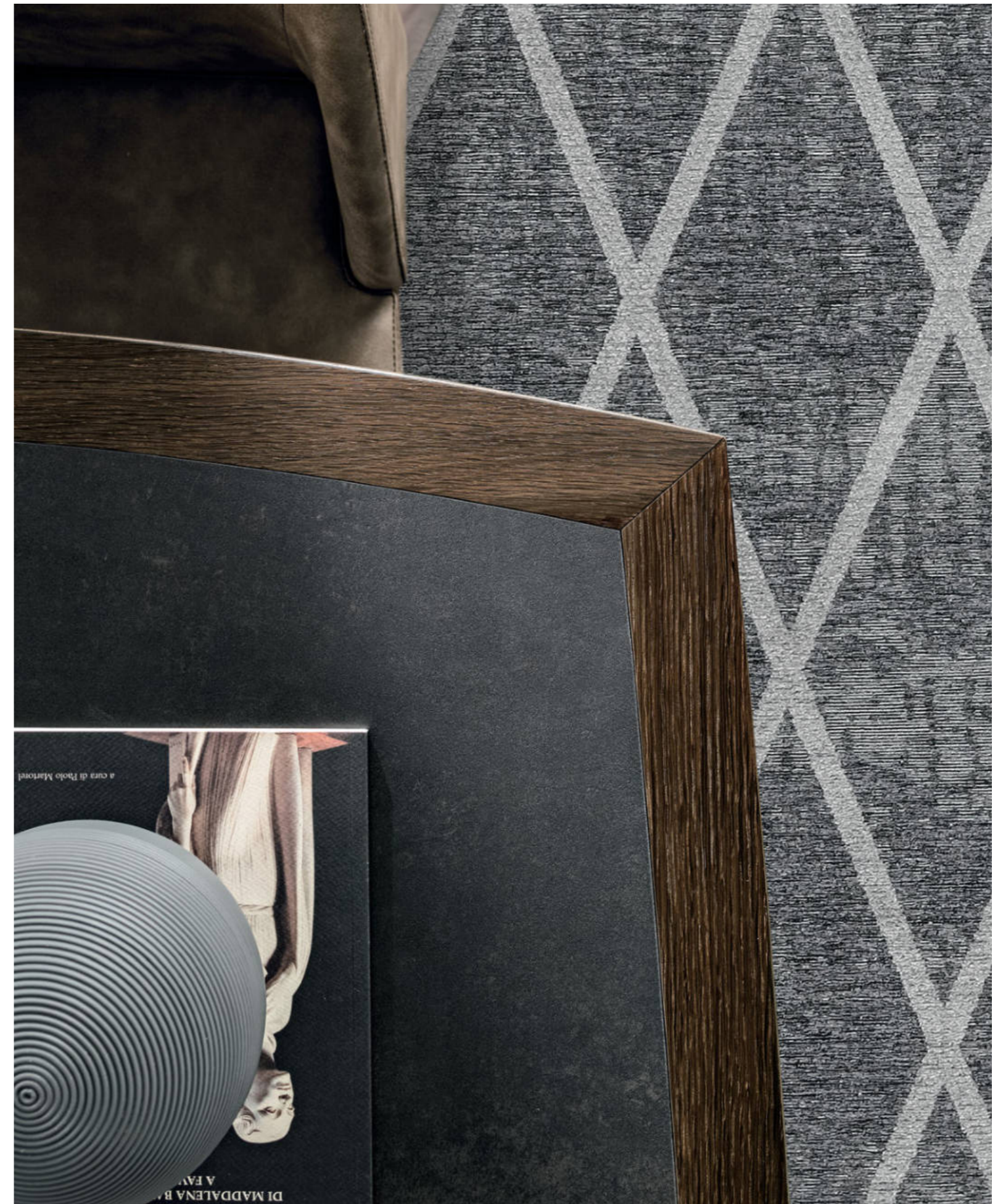



DOPPIO PASSO ALLUNGABILE

Tavolo Doppio Passo chiuso / Shut Doppio Passo table

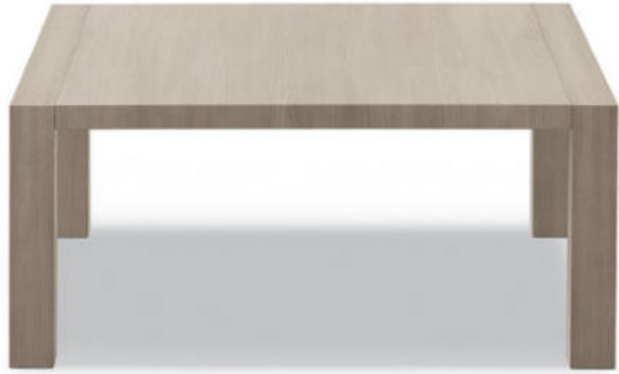

Tavolo Doppio Passo con una allunga / Doppio Passo table with one extension



Tavolo Doppio Passo con due allunghe / Doppio Passo table with two extensions



← **Pagina precedente**
Tavolo allungabile Doppio Passo struttura legno frassino oriente.
L 170 (215/260) P 100 H 75 cm

Sedia Skinny cat. B ecopelle vintage 102.
L 46 P 56 H 95/48 cm

Madia Diagonal Var. A materico frassino oriente, metallo bianco gesso 121.
L 219 P 51 H 85 cm

Mensole Ring materico frassino oriente e metallo bianco gesso 121.
L 144 P 26 H 27 cm

Orologio 670.

Tappeto Diagonal.

Preceding page
Doppio Passo extending table with textured eastern ash frame.
L 160 (205/250) W 90 H 75 cm

Skinny chair upholstered with cat. B vintage 102 eco-leather.
W 46 D 56 H 95/48 cm

Diagonal Var. A sideboard in textured eastern ash and chalk white 121 metal.
W 219 D 51 H 85 cm

Ring shelves in textured eastern ash and chalk white 121 metal.
L 144 D 26 H 27 cm

670 clock.

Diagonal rug.



DOPPIO PASSO

Tavolo Doppio Passo struttura legno laccato
pore aperto hot 227.
L 170 (215/260) P 100 H 75 cm

Sedie Skinny cat 1/one atom 34.
L 46 P 56 H 95/48 cm

Madia Atlante laccato opaco hot 127 e
specchio grigio 383.
L 192 P 54 H 76 cm

Pouf Guccino cat. b ecopelle vintage 107 e
laccato opaco hot 127.
Ø 40 H 53 cm

Tappeto Frame.

Doppio Passo table with open-pore hot grey
227 lacquered wood frame.
L 170 (215/260) W 100 H 75 cm

Skinny cat 1/one atom 34 chairs.
W 46 D 56 H 95/48 cm

Matt hot grey 127 lacquered Atlante sideboard
with grey 383 mirror.
W 192 D 54 H 76 cm

Guccino pouf upholstered with cat. b vintage
107 eco-leather and lacquered matt hot grey
127.
Ø 40 H 53 cm

Frame rug.

DOPPIO PASSO

Pagina successiva

Tavolo Doppio Passo struttura legno rovere termocotto.
L 170 (215/260) P 100 H 75 cm

Sedia Lola struttura legno rovere termocotto, cat. b ecopelle extrema 12.
L 55 P 53 H 81/47 cm

Sedia Lolita struttura legno rovere termocotto, cat. b hugo 04.
L 51 P 56 H 79/47 cm

Next page

Doppio Passo table with a heat-treated oak wood frame.
L 170 (215/260) W 100 H 75 cm

Lola chair with a heat-treated oak wood frame upholstered with cat. b extrema 12 eco-leather.
W 55 D 53 H 81/47 cm

Lolita chair with a heat-treated oak wood frame upholstered with cat. b hugo 04 fabric.
W 51 D 56 H 79/47 cm

DOPPIO PASSO

misure / size

L /W170 (215-260) P/D 100 H 75 cm

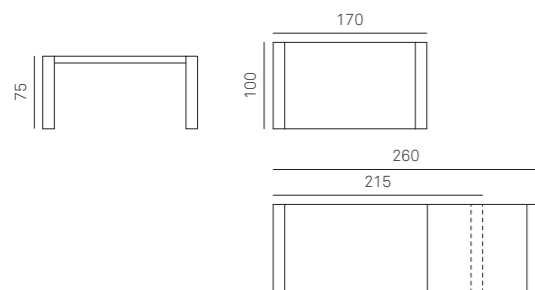

FINITURE TOP E BASE / BASE AND TOP FINISHES

ESSENZE / WOOD FINISHES



LGN-FO
Frassino Oriente
Eastern Ash



LGN-RT
Rovere Termocotto
Heat-treated Oak

MATERICO NODATO / KNOTTED TEXTURED



MT-RNC
Nodato chiaro
Light Knotted

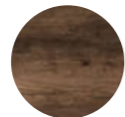

MT-RNS
Nodato scuro
Dark knotted

MATERICO ESSENZA / TEXTURED WOOD



MT-FO
Frassino Oriente
Eastern Ash



MT-RT
Rovere termocotto
Heat-treated Oak

MATERICO / TEXTURED



MT-CC
Cemento chiaro
Light cement



MT-CS
Cemento scuro
Dark cement



MT-CV
Cemento Cava
Cava cement

LEGNO LACCATO PORO APERTO / OPEN PORE LACQUERED WOOD



221 PA
Bianco Gesso
Chalk white



222 PA
Panna
Cream



224 PA
Madreperla
Mother of pearl



227 PA
Hot
Hot grey



230 PA
Grigio Piacenza
Piacenza grey



250 PA
Canapa
Hemp

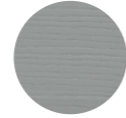

252 PA
Pomice
Pumice

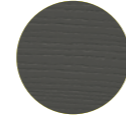

260 PA
Antracite
Anthracite



INFINITY

Tavolo Infinity allungabile piano materico cemento scuro, struttura peltro.
L 280/330-380 P 110 H 75 cm

Sedia Tiffany Gonna cat. b linara 08 e cat. c lino froissè 100.
L 46 P 50 H 83/47 cm

Pouff Cookie cat. c lino froissè 100 filo 0856.
L 47 P 47 H 46 cm

Libreria Movida struttura metallo antracite 160, ripiani materico nodato chiaro.
L 74 P 38 H 190 cm

Extending Infinity table with dark textured cement top and pewter frame.
L 280/330-380 W 110 H 75 cm

Tiffany Gonna chair in cat. b linara 08 and cat. c froissè linen 100 fabric.
W 46 D 50 H 83/47 cm

Cookie pouf in cat. c froissè linen 100 fabric, 0856 yarn.
W 47 D 47 H 46 cm

Movida bookcase with anthracite 160 metal frame and textured light knotted shelves.
W 74 D 38 H 190 cm



Tante soluzioni. Il tavolo risponde ad esigenze diverse: fisso per chi ha le idee chiare, allungabile per spazi in movimento o su misura per ambienti fuori dagli schemi.

The table caters to different needs: fixed for people who know exactly what they want, extending for ever-changing spaces or custom made for outside-the-box interiors.

INFINITY

Tavolo Infinity fisso piano materico maya bronze, struttura peltro.
L 140 P 140 H 75 cm

Sedia York struttura legno rovere termocotto, rivestimento cat. b ecopelle vintage 106.
L 47 P 61 H 92/48 cm

Libreria Movida struttura metallo antracite 160, ripiani maya bronze.
L 74 P 38 H 190 cm.

Wallpaper WPT552.

Fixed Infinity table with a textured maya bronze top and a pewter frame.
L 140 W 140 H 75 cm

York chair with a heat-treated oak wood frame upholstered with cat. b vintage 106 eco-leather.
W 47 D 61 H 92/48 cm

Movida bookcase with an anthracite 160 metal frame and maya bronze shelves.
W 74 D 38 H 190 cm.

WPT552 wallpaper.



INFINITY



Piano materico frassino oriente, struttura metallo bianco gesso 121.
Textured eastern ash top, chalk white 121 metal frame.

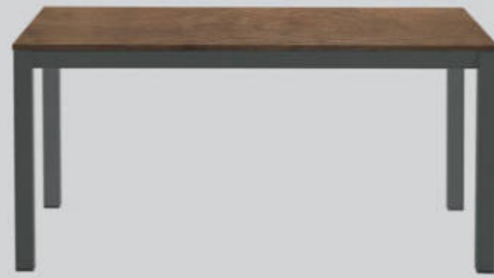

Piano materico nodato scuro, struttura metallo antracite 160.
Textured dark knotted top, anthracite 160 metal frame.

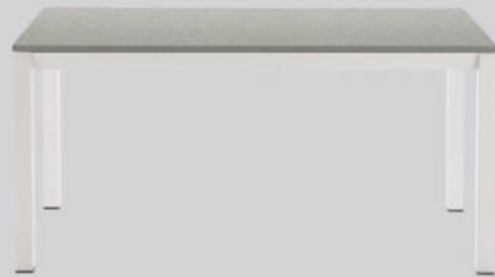

Piano materico cemento chiaro, struttura metallo bianco gesso 121.
Textured light knotted top, chalk white 121 metal frame.



Piano laccato opaco smoke 128, struttura metallo smoke 128.
Matt smoke 128 lacquered top, smoke 128 metal frame.



Piano laccato opaco carta da zucchero 155, struttura metallo carta da zucchero 155.
Matt blue grey 155 lacquered top, blue grey 155 metal frame.

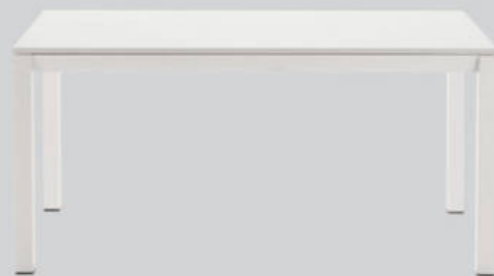

Piano laccato opaco bianco gesso 121, struttura metallo bianco gesso 121.
Chalk white 121 lacquered top, chalk white 121 metal frame.

INFINITY

Tavolo Infinity piano materico nodato chiaro, struttura metallo bianco gesso 121.
L 160/200-240 P 90 H 75 cm
Sedia Tiffany Gonna cat. c lino froissé 011, 123, 010, 019.
L 46 P 50 H 83/47 cm

Wallpaper WPT 560.

Infinity table with textured light knotted top, chalk white 121 metal frame.
L 160/200-240 W 90 H 75 cm

Tiffany Gonna chair in cat. c froissé linen 011, 123, 010, 019 fabric.
W 46 D 50 H 83/47 cm

WPT 560 wallpaper.



INFINITY

misure / size

rettangolare allungabile e fisso / extending and fixed rectangular

140 x 80

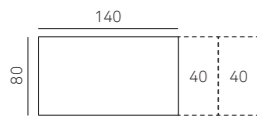

160 x 90

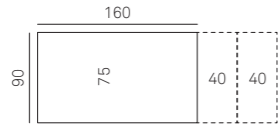

180 x 90

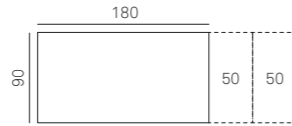

200 x 100

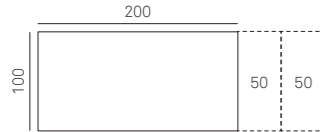

220 x 110

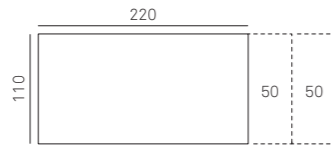

quadrato fisso / fixed square

100 x 100

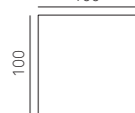
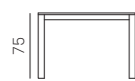

140 x 140

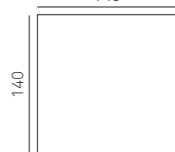

rettangolare a misura / rectangular to size

P/D 90/100/110

L/W 130 ÷ 170 (2 prolunghe / extensions da 40)

L/W 171 ÷ 190 (2 prolunghe / extensions da 50)

L/W 191 ÷ 220 (2 prolunghe / extensions da 50)

L/W 221 ÷ 250 (2 prolunghe / extensions da 50)

L/W 251 ÷ 280 (2 prolunghe / extensions da 50)

FINITURE BASAMENTO / BASE FINISHES

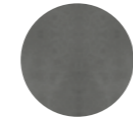

DI SERIE / STANDARD
Finitura Peltro
Pewter finish



DI SERIE / STANDARD
Finitura Antracite
Anthracite finish

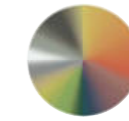

colori laccati opachi a campionario
(vedi pagina 333)
choice of matt lacquer colours from
our range (see page 333)

FINITURE PIANO / TOP FINISHES

MATERICO NODATO / KNOTTED TEXTURED



MT-RNC
Nodato chiaro
Light Knotted

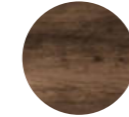

MT-RNS
Nodato scuro
Dark knotted

MATERICO ESSENZA / TEXTURED WOOD



MT-FO
Frassino Oriente
Eastern Ash



MT-RT
Rovere termocotto
Heat-treated Oak

MATERICO PORO APERTO / OPEN PORE TEXTURED



MT-PA BG
Bianco Gesso
Chalk white



MT-PA MP
Madreperla
Mother of pearl

MATERICO OPACO / MATT TEXTURED



MT-OC BG
Bianco Gesso
Chalk white



MT-OC MP
Madreperla
Mother of pearl



MT-OC AN
Antracite
Anthracite

MATERICO / TEXTURED



MT-CC
Cemento chiaro
Light cement

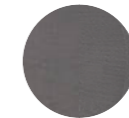

MT-CS
Cemento scuro
Dark cement

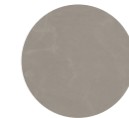

MT-CV
Cemento Cava
Cava cement

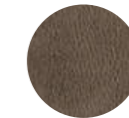

MT-MB
Maya Bronze

LEGNO LACCATO PORO APERTO / OPEN PORE LACQUERED WOOD



221 PA
Bianco Gesso
Chalk white



222 PA
Panna
Cream



224 PA
Madreperla
Mother of pearl



227 PA
Hot
Hot grey



230 PA
Grigio Piacenza
Piacenza grey



250 PA
Canapa
Hemp

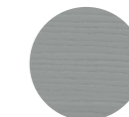

252 PA
Pomice
Pumice

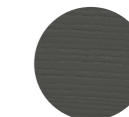

260 PA
Antracite
Anthracite

LACCATI / LACQUERS



colori laccati opachi a campionario
(vedi pagina 333)
choice of matt lacquer colours
from our range (see page 333)

sedie

chairs

Le sedute rendono confortevole e accogliente la vita quotidiana. In ogni stanza della casa, dal living alla camera da letto, stand-alone o in gruppo, le sedie sono funzionali ma anche estremamente decorative.

Chairs add a touch of welcoming comfort to everyday life. In every corner of the home, from the living room to the bedroom, alone or in groups, chairs make a functional and, at the same time, extremely decorative feature.



YORK

misure / size L/W 47 P/D 61 H 92/48 cm

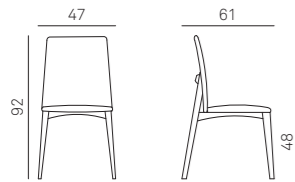

FINITURE STRUTTURA / FRAME FINISHES

ESSENZE / WOOD FINISHES



LGN-RT
Rovere termocotto
Heat-treated Oak



LGN-FO
Frassino oriente
Eastern ash

LEGNO LACCATO PORO APERTO / OPEN-PORE LACQUERED WOOD



221 PA
Bianco Gesso
Chalk white



222 PA
Panna
Cream



224 PA
Madreperla
Mother of pearl



227 PA
Hot
Hot grey



230 PA
Grigio Piacenza
Piacenza grey



250 PA
Canapa
Hemp



252 PA
Pomice
Pumice

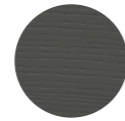

260 PA
Antracite
Anthracite

RIVESTIMENTO / COVERING

Rivestimento in econabuk, ecopelle e pelle
Eco-nubuck, eco-leather and leather upholstery



YORK

Sedia York struttura
legno rovere termocotto,
rivestimento cat.b ecopelle
vintage 106.
L 47 P 61 H 92/48 cm

York chair with a heat-treated
oak wood frame upholstered
with cat. b vintage 106
eco-leather.
W 47 D 61 H 92/48 cm



LOLITA

Sedia Lolita

- 01. struttura legno frassino oriente, rivestimento cat. b ecopelle extrema 34.
 - 02. struttura legno laccato poro aperto madreperla 224, rivestimento cat. c tino froissè 20.
 - 03. struttura legno laccato poro aperto pomice 252, rivestimento cat. d nubes 09.
 - 04. struttura legno laccato poro aperto antracite 260, rivestimento cat. d nubes 09.
- L 51 P 56 H 79/47 cm

Wallpaper WPT 533.

Lolita chair

- 01. eastern ash wood frame upholstered with cat. b extrema 34 eco-leather.
 - 02. open-pore mother of pearl 224 lacquered wood frame upholstered with cat. c froissè linen 20.
 - 03. open-pore pumice 252 lacquered wood frame upholstered with cat. d nubes 09.
 - 04. open-pore anthracite 260 lacquered wood frame upholstered with cat. d nubes 09.
- W 51 D 56 H 79/47 cm

WPT 533 wallpaper.



01.



02.



03.



04.

LOLITA e LOLA

Lolita misure / size L/W 51 P/D 56 H 79/47 cm

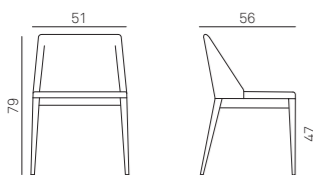

Lola misure / size L/W 55 P/D 53 H 81/47 cm

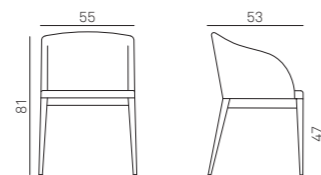

FINITURE STRUTTURA / FRAME FINISHES

ESSENZE / WOOD FINISHES



LGN-RT
Rovere termocotto
Heat-treated Oak



LGN-FO
Frassino orientale
Eastern ash

LEGNO LACCATO PORO APERTO / OPEN-PORE LACQUERED WOOD



221 PA
Bianco Gesso
Chalk white



222 PA
Panna
Cream



224 PA
Madreperla
Mother of pearl



227 PA
Hot
Hot grey



230 PA
Grigio Piacenza
Piacenza grey



250 PA
Canapa
Hemp

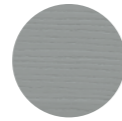

252 PA
Pomice
Pumice

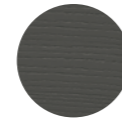

260 PA
Antracite
Anthracite

RIVESTIMENTO / COVERING

Econabuk, ecopelle e pelle
Eco-nubuck, eco-leather and leather upholstery



Tessuti del campionario
Our range of fabrics



Sedia Lolita

- 01. struttura legno rovere termocotto, rivestimento cat. b hugo 04.
- 02. struttura legno rovere termocotto, rivestimento cat. b ecopelle vintage 102.
- 03. struttura legno rovere termocotto, rivestimento cat. b ecopelle vintage 107.

Lolita chair

- 01. heat-treated oak wood frame upholstered with cat. b hugo 04 fabric.
 - 02. heat-treated oak wood frame upholstered with cat. b vintage 102 eco-leather.
 - 03. heat-treated oak wood frame upholstered with cat. b vintage 107 eco-leather.
- W 51 D 56 H 79/47 cm



^
Sedia Lola struttura legno rovere termocotto, rivestimento cat. d nubes 10. L 55 P 53 H 81/47 cm

Lola chair with heat-treated oak wood frame upholstered with cat. d nubes 10 fabric. W 55 D 53 H 81/47 cm

Sedia Lola
01. struttura legno rovere termocotto, rivestimento cat. d nubes 07.
02. struttura legno rovere termocotto, rivestimento cat. d nubes 09.
03. struttura legno rovere termocotto, rivestimento cat. c lino froissè 100. L 55 P 53 H 81/47 cm
Wallpaper WPT535.



LOLA

01.

02.

03.

Lola chair
01. heat-treated oak wood frame upholstered with cat. d nubes 07 fabric. >
02. heat-treated oak wood frame upholstered with cat. d nubes 09 fabric.
03. heat-treated oak wood frame upholstered with cat. c froissè linen 100 fabric. W 55 D 53 H 81/47 cm
WPT535 wallpaper.



Sedie BeA struttura legno rovere termocotto.
L 42 P 53 H 78/44 cm

Bea chairs with a heat-treated oak wood
frame.
W 42 D 53 H 78/44 cm

BEA

misure / size L/W 42 P/D 53 H 78/44 cm

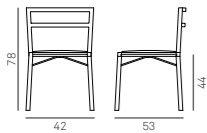

FINITURE STRUTTURA / FRAME FINISHES

ESSENZE / WOOD FINISHES



LGN-RT
Rovere termocotto
Heat-treated Oak

LEGNO LACCATO PORO APERTO / OPEN-PORE LACQUERED WOOD



221 PA
Bianco Gesso
Chalk white



222 PA
Panna
Cream



224 PA
Madreperla
Mother of pearl



227 PA
Hot
Hot grey

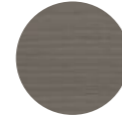

230 PA
Grigio Piacenza
Piacenza grey



250 PA
Canapa
Hemp

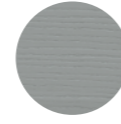

252 PA
Pomice
Pumice

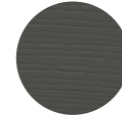

260 PA
Antracite
Anthracite



BEA

TIME

01. Sedie Time struttura legno rovere termocotto, rivestimento cat. b ecopelle vintage 107.
02. Sedia Time struttura legno frassino oriente, rivestimento cat. b ecopelle vintage 107.
L 43 P 52 H 80/44 cm

01. Time chairs with a heat-treated oak wood frame upholstered with cat. b vintage 107 eco-leather.
02. Time chair with an eastern ash wood frame upholstered with cat. b vintage 107 eco-leather.
W 43 D 52 H 80/44 cm

TIME

misure / size L/W 43 P/D 52 H 80/44 cm

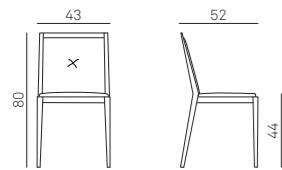

FINITURE STRUTTURA / FRAME FINISHES

ESSENZE / WOOD FINISHES



LGN-FO
Frassino Oriente
Eastern Ash

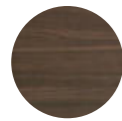

LGN-RT
Rovere termocotto
Heat-treated Oak

LEGNO LACCATO PORO APERTO / OPEN-PORE LACQUERED WOOD



221 PA
Bianco Gesso
Chalk white



222 PA
Panna
Cream



224 PA
Madreperla
Mother of pearl



227 PA
Hot
Hot grey

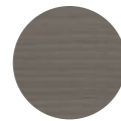

230 PA
Grigio Piacenza
Piacenza grey



250 PA
Canapa
Hemp

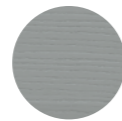

252 PA
Pomice
Pumice

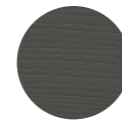

260 PA
Antracite
Anthracite

RIVESTIMENTO / COVERING

Econabuk, ecopelle e pelle
Eco-nubuck, eco-leather and leather upholstery



Tessuti del campionario
Our range of fabrics



BETTY



Sedia Betty
 01. cat. b ecopelle vintage 102.
 02. cat. 1/one atom 34.
 03. cat. b econabuk 12.
 04. cat. b ecopelle 01.
 05. cat. b econabuk 11.
 06. cat. b ecopelle 15.
 L 45 P 54 H 81/46 cm

Wallpaper WPT 535.
 Wallpaper WPT 527.

Betty chair
 01. cat. b vintage 102 eco-leather.
 02. cat. 1/one atom 34.
 03. cat. b eco-nubuck 12.
 04. cat. b eco-leather 01.
 05. cat. b eco-nubuck 11.
 06. cat. b eco-leather 15.
 W 45 D 54 H 81/46 cm

WPT 535 wallpaper.
 WPT 527 wallpaper.

misure / size L/W 45 P/D 54 H 81/46

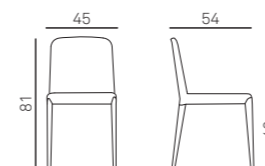

RIVESTIMENTO / COVERING

Econabuk, ecopelle e pelle
 Eco-nubuck, eco-leather and leather upholstery





Sedia Skinny
 01. cat. b ecopelle 16.
 02. cat. b econabuk 02.
 L 46 P 56 H 95/48 cm
 Wallpaper WPT 512.

Skinny chair
 01. cat. b eco-leather 16.
 02. cat. b eco-nubuck 02.
 W 46 D 56 H 95/48 cm
 WPT 512 wallpaper.



SKINNY

misure / size L/W 46 P/D 56 H 95/48 cm

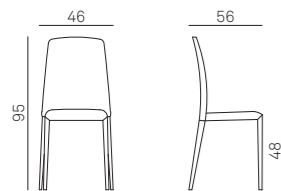

RIVESTIMENTO / COVERING

Econabuk, ecopelle e pelle
 Eco-nubuck, eco-leather and leather upholstery



TIFFANY

Sedia Tiffany
01. struttura legno laccato poro aperto pomice 252, rivestimento cat. d nubes 09.
02. struttura legno laccato poro aperto madreperla 224, rivestimento cat. b hugo 04.
03. struttura legno laccato poro aperto madreperla 224, rivestimento cat. b ecopelle vintage. 107
04. struttura legno laccato poro aperto antracite 260, rivestimento cat. b ecopelle vintage 102.
L 46 P 50 H 83/47 cm

Wallpaper WPT 511.

Tiffany chair
01. open-pore pumice 252 lacquered wood frame upholstered with cat. d nubes 09 fabric.
02. open-pore mother of pearl 224 lacquered wood frame upholstered with cat. b hugo 04 fabric.
03. open-pore mother of pearl 224 lacquered wood frame upholstered with cat. b vintage
eco-leather. 107
04. wooden frame in open-pore anthracite 260 lacquer upholstered with cat. b vintage 102
eco-leather.
W 46 D 50 H 83/47 cm
WPT 511 wallpaper.

01.

02.

03.

04.

Sedia Tiffany struttura legno laccato poro aperto antracite 260, rivestimento cat. b econabuk 07. >
L 46 P 50 H 83/47 cm

Tiffany chair with an open-pore anthracite 260 lacquered wood frame upholstered with cat. b eco-nubuck 07.
W 46 D 50 H 83/47 cm

TIFFANY

misure / size L/W 46 P/D 50 H 83/47 cm

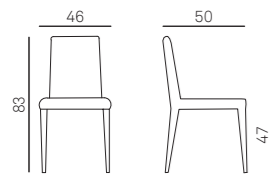

FINITURE STRUTTURA / FRAME FINISHES

LEGNO LACCATO PORO APERTO / OPEN-PORE LACQUERED WOOD



221 PA
Bianco Gesso
Chalk white



222 PA
Panna
Cream



224 PA
Madreperla
Mother of pearl



227 PA
Hot
Hot grey

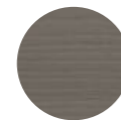

230 PA
Grigio Piacenza
Piacenza grey



250 PA
Canapa
Hemp

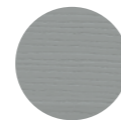

252 PA
Pomice
Pumice

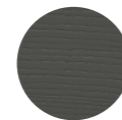

260 PA
Antracite
Anthracite

RIVESTIMENTO / COVERING

Econabuk, ecopelle e pelle
Eco-nubuck, eco-leather and leather upholstery



Tessuti del campionario
Our range of fabrics





Sedia Tiffany Gonna in vari colori e tessuti.
L 46 P 50 H 83/47 cm

Tiffany Gonna chair in various colours and fabrics.
W 46 D 50 H 83/47 cm

TIFFANY GONNA



TIFFANY GONNA

misure / size L/W 46 P/D 50 H 83/47 cm

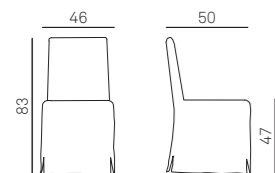

RIVESTIMENTO / COVERING

Tessuti del campionario
Our range of fabrics

**Non disponibile in ecopelle,
econabuk e pelle**
Not available in eco-leather,
eco-nubuck or leather



madie

sideboards

Appartengono al passato e alla tradizione, ma oggi tornano con soluzioni originali e adatte a ogni tipo di spazio. Le madie aprono una nuova dimensione del design mentre piatti, bicchieri e stoviglie ritrovano casa.

A blast from the past, the sideboard is a part of tradition revived for today's homes with original solutions designed for spaces of all kinds. Sideboards bring a new dimension to contemporary design, while plates, glassware and crockery in general find a new home.



SIR



Madia Sir S04 struttura materico intreccio chiaro, elemento Sir materico rovere termocotto e basamento metallo antracite 160.
L 216 P 51 H 90 cm

Sir S04 sideboard with a textured light Intreccio carcass, Sir element in textured heat-treated oak with an anthracite 160 metal base.
W 216 D 51 H 90 cm



SIR

Madia Sir S03 struttura materico intreccio chiaro, elemento Sir materico rovere termocotto e basamento metallo antracite 160.

L 216 P 51 H 66 cm

Collezione Natural Style S.

Sir S03 sideboard with a textured light Intreccio carcass, Sir element in textured heat-treated oak with an anthracite 160 metal base.

W 216 D 51 H 66 cm

Natural Style S collection.

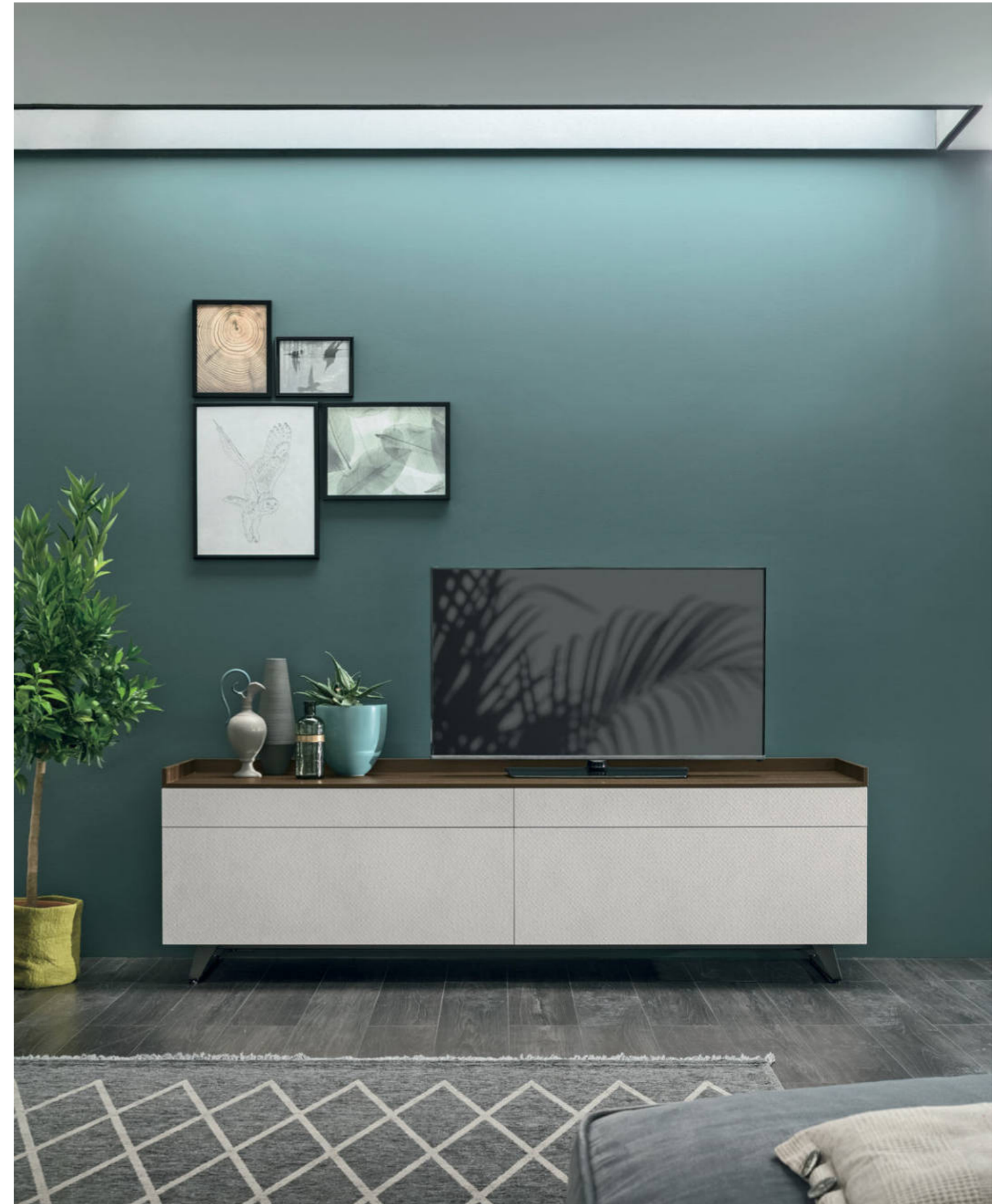

SIR

Madia Sir S02 struttura laccato opaco salvia 159, elemento Sir legno rovere termocotto. L 270 P 40 H 54 cm

Tavolo Plinto piano vetro trasparente 320, struttura legno rovere termocotto e metallo antracite 160. L 240 P 110 H 75 cm

Sedie York struttura legno rovere termocotto, rivestimento cat. b econabuk 12. L 47 P 61 H 92/48 cm

Tappeto Black & White.

Sir S02 sideboard with a matt sage 159 lacquered carcass, Sir element in heat-treated oak wood. W 270 D 40 H 54 cm

Plinto table with a transparent 320 glass top, wooden heat-treated oak and anthracite 160 metal frame. L 240 W 110 H 75 cm

York chairs with a heat-treated oak wood frame upholstered with cat. b eco-nubuck 12. W 47 D 61 H 92/48 cm

Black & White rug.



SIR

misure / size L/W 216 P/D 40 H 54 cm L/W 270 P/D 40 H 54 cm L/W 216 P/D 51 H 66 cm L/W 216 P/D 51 H 90 cm

S01

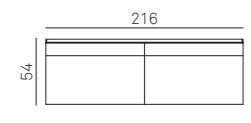

S02

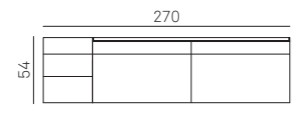

S03

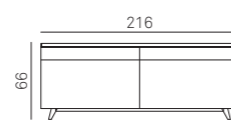

S04

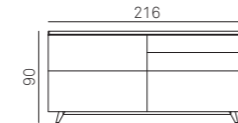

FINITURE FRONTALI E ELEMENTO SIR / DOORS FINISHES AND SIR ELEMENT

ESSENZE / WOOD FINISHES



LGN-FO
Frassino Oriente
Eastern Ash

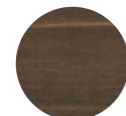

LGN-RT
Rovere termocotto
Heat-treated Oak

MATERICO ESSENZA / TEXTURED WOOD



MT-FO
Frassino Oriente
Eastern Ash

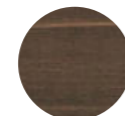

MT-RT
Rovere termocotto
Heat-treated Oak

MATERICO NODATO / KNOTTED TEXTURED



MT-RNC
Nodato chiaro
Light Knotted



MT-RNS
Nodato scuro
Dark knotted

MATERICO / TEXTURED



MT-CC
Cemento chiaro
Light cement



MT-CS
Cemento scuro
Dark cement

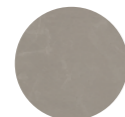

MT-CV
Cemento Cava
Cava cement

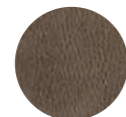

MT-MB
Maya Bronze



MT-INT C
Intreccio chiaro



MT-INT S
Intreccio scuro

Elemento Sir non disponibile nelle finiture intreccio.
Sir element not available in Intreccio finishes.

MATERICO PORO APERTO / OPEN PORE TEXTURED



MT-PA BG
Bianco Gesso
Chalk white



MT-PA MP
Madreperla
Mother of pearl

MATERICO OPACO / MATT TEXTURED



MT-OC BG
Bianco Gesso
Chalk white



MT-OC MP
Madreperla
Mother of pearl



MT-OC AN
Antracite
Anthracite

LACCATI / LACQUERS



colori laccati opachi e lucidi a
campionario (vedi pagina 333)
choice of gloss and matt lacquer
colours from our range (see page 333)

Elemento Sir non disponibile nelle finiture in laccato lucido.
Sir element not available in gloss lacquered colours.

LEGNO LACCATO PORO APERTO / OPEN-PORE LACQUERED WOOD



221 PA
Bianco Gesso
Chalk white

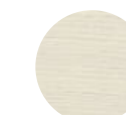

222 PA
Panna
Cream



224 PA
Madreperla
Mother of pearl



227 PA
Hot
Hot grey



230 PA
Grigio Piacenza
Piacenza grey



250 PA
Canapa
Hemp



252 PA
Pomice
Pumice

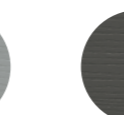

260 PA
Antracite
Anthracite

FINITURE BASAMENTO / BASE FINISHES

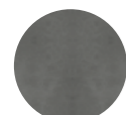

DI SERIE / STANDARD
Finitura Peltro
Pewter finish



DI SERIE / STANDARD
Finitura Antracite
Anthracite finish



colori laccati opachi a
campionario (vedi pagina 333)
choice of matt lacquer colours
from our range (see page 333)



a sinistra
Madia Regolo R01 struttura laccato opaco
zafferano 158, inserto materico nodato
scuro e basamento metallo zafferano 158.
L 108 P 40 H 147 cm

a destra
Madia Regolo R02 struttura materico opaco
madreperla, inserto materico nodato scuro.
basamento metallo madreperla 124.
L 108 P 40 H 147 cm

on the left
Regolo R01 sideboard with a matt saffron
158 lacquered carcass, textured dark
knotted insert and saffron 158 metal base.
W 108 D 40 H 147 cm

on the right
Regolo R02 sideboard with a matt mother
or pearl lacquered carcass, textured dark
knotted insert. Mother of pearl 124 metal
base.
W 108 D 40 H 147 cm

REGOLO



REGOLO

Madia Regolo R05 struttura materico opaco madreperla, inserto materico nodato scuro e basamento metallo madreperla 124. L 180 P 51 H 93,5 cm

Collezione Quadri Loft Style S.

Tappeto Frame.

Regolo R05 sideboard with a matt mother or pearl lacquered carcass, textured dark knotted insert and Mother or pearl 124 metal base. W 180 D 51 H 93.5 cm

Loft Style S Quadri collection.

Frame rug.



REGOLO

Madie Regolo R03 struttura materico opaco bianco gesso, inserto materico opaco antracite.
L 108 P 40 H 147,5 cm

Sedia Lola struttura legno rovere termocotto, rivestimento cat. c lino froissé 123.
L 55 P 53 H 81/47 cm

Regolo R03 sideboards with a textured matt chalk white carcass and an textured anthracite matt insert.
W 108 D 40 H 147,5 cm

Lola chair with a heat-treated oak frame upholstered with cat. c froissé linen 123 fabric.
W 55 D 53 H 81/47 cm





REGOLO

Madia Regolo R06 struttura materico opaco bianco gesso, inserto materico frassino oriente e basamento metallo antracite 160. L 216 P 51 H 93,5 cm

Regolo R06 sideboard with a textured matt chalk white carcass, a textured eastern ash insert and an anthracite 160 metal base. W 216 D 51 H 93.5 cm



REGOLO

misure / size

P/D 40 cm

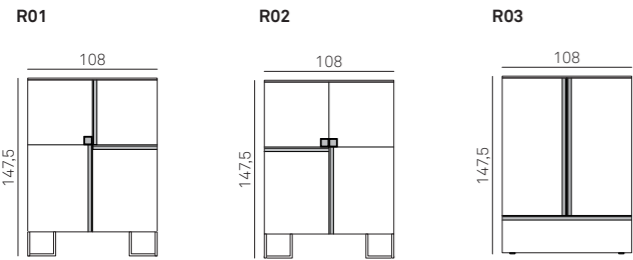

P/D 51 cm

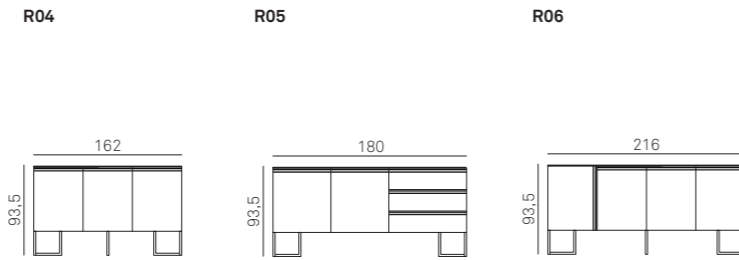

FINITURE STRUTTURA / STRUCTURE FINISHES

ESSENZE / WOOD FINISHES

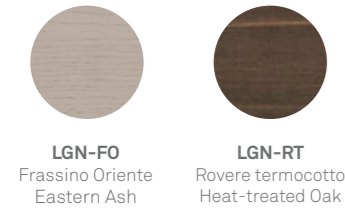

MATERICO ESSENZA / TEXTURED MATERIC

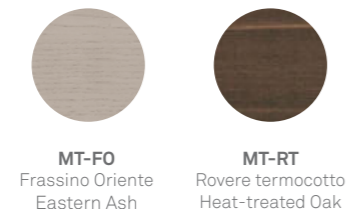

MATERICO NODATO / KNOTTED TEXTURED

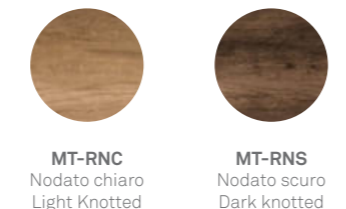

MATERICO OPACO / MATT MATERIC

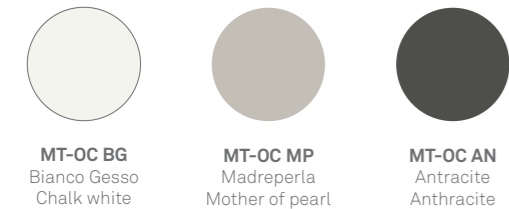

MATERICO PORO APERTO / OPEN PORE MATERIC



MATERICO / TEXTURED



LACCATI / LACQUERS

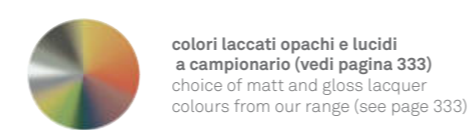

LEGNO LACCATO PORO APERTO / OPEN-PORE LACQUERED WOOD

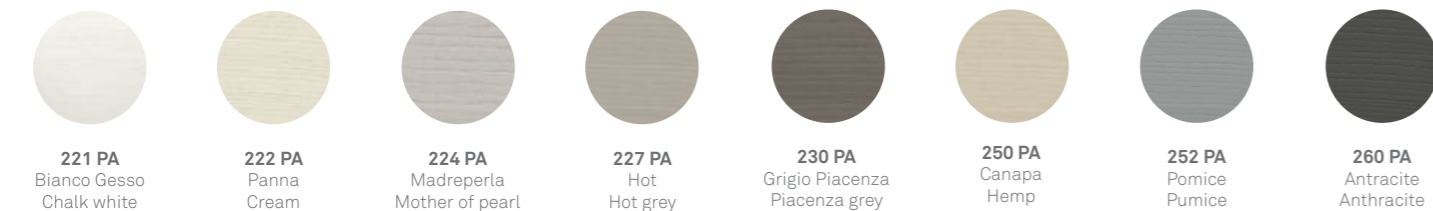

FINITURE MANIGLIA REGOLO / REGOLO HANDLE FINISHES

MATERICO ESSENZA / TEXTURED WOOD



MATERICO NODATO / KNOTTED TEXTURED

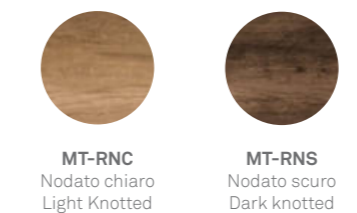

MATERICO / TEXTURED



MATERICO OPACO / MATT TEXTURED

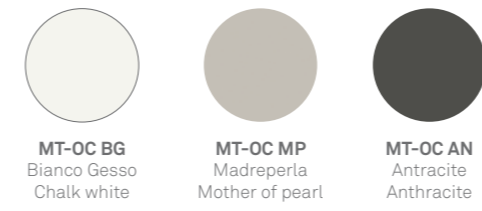

MATERICO PORO APERTO / OPEN PORE TEXTURED



LACCATI / LACQUERS

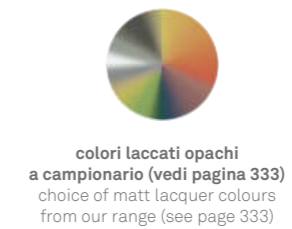

METALLO LACCATO / LACQUERED METAL



LEGNO LACCATO PORO APERTO / OPEN-PORE LACQUERED WOOD



FINITURE BASAMENTO / BASE FINISHES

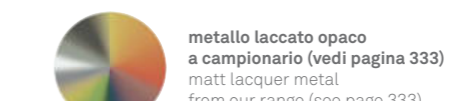
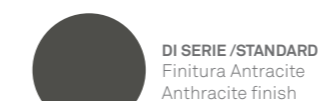



REMIX

Madia Remix X02 struttura materico opaco madreperla, materico nodato chiaro e metallo antracite 160.
L 162 P 51 H 85,5 cm

Collezione Quadri Natural Style M.

Remix X02 sideboard with a matt mother of pearl, textured light knotted and anthracite metal 160 carcass.
W 162 D 51 H 85.5 cm

Natural Style M Quadri collection.





REMIX

Madia Remix X01 struttura laccato opaco
carta da zucchero 155 e salvia 159.
Basamento metallo antracite 160.
L 108 P 40 H 129,5 cm

Remix X01 sideboard with a matt blue grey 155
and sage 159 lacquered carcass. Anthracite
160 metal base.
W 108 D 40 H 129.5 cm



L'angolo tagliato è il tratto distintivo di Remix: l'anta asimmetrica e l'accostamento di materiali diversi conferisce originalità ed equilibrio alla composizione.

The angled door is a distinctive feature of the Remix model: the asymmetric door and the combination of different finishes give the arrangement an original yet balanced appeal.

REMIX

Madia Remix X05 struttura materico cemento chiaro, elemento Sir legno frassino orientale e metallo antracite 160. L 180 P 51 H 84 cm

Collezione Quadri Elegance Style M.

Remix X05 sideboard with a light textured cement carcass, Sir element in eastern ash wood and anthracite 160 metal. W 180 D 51 H 84 cm

Elegance Style M Quadri collection.



METROPOLIS





< METROPOLIS

Pagina precedente
 Madia Metropolis A03 materico intreccio
 chiaro e metallo antracite 160.
 L 180 P 51 H 85,5 cm
 Collezione Quadri Elegance Style S.
 Tappeto Dots.

Preceding page
 Metropolis A03 sideboard in textured light
 Intreccio and anthracite 160 metal.
 W 180 D 51 H 85,5 cm
 Elegance Style S Quadri collection.
 Dots rug.





METROPOLIS

Madia Metropolis B01 struttura materico rovere termocotto, basamento metallo antracite 160.
L 180 P 51 H 85,5 cm
Wallpaper WPT 513.

Metropolis B01 sideboard with a textured heat-treated oak carcass and an anthracite 160 metal base.
W 180 D 51 H 85.5 cm
WPT 513 wallpaper.

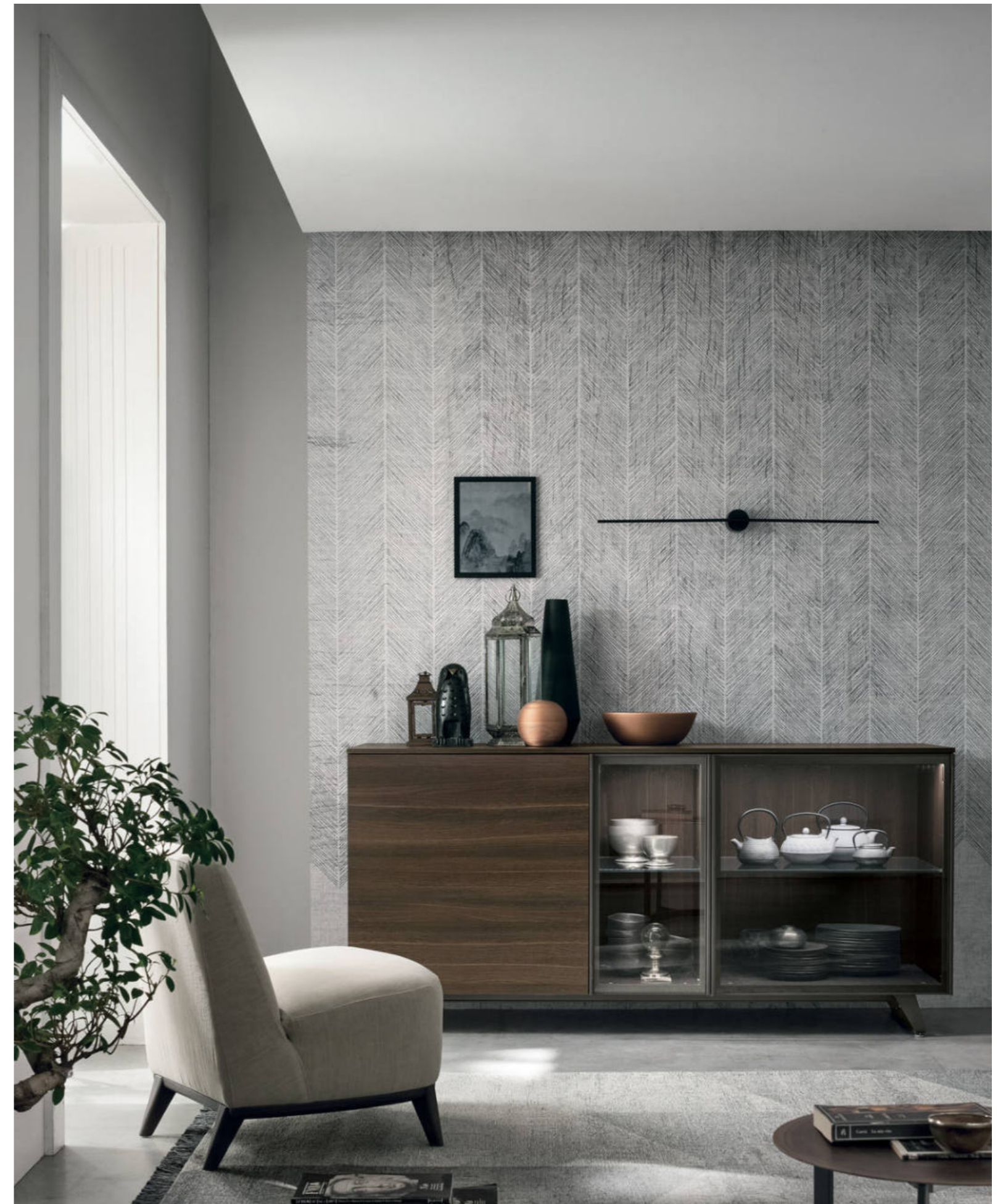

METROPOLIS

Madia Metropolis struttura
materico rovere termocotto,
basamento metallo antracite 160.
L 108 H 157,5 P 40 cm

Metropolis sideboard with a
textured heat-treated oak carcass
and an anthracite 160 metal base.
W 108 H 157.5 D 40 cm



METROPOLIS

Madia Metropolis A06 struttura
materico rovere termocotto,
basamento metallo antracite 160.
L 216 P 51 H 85,5 cm

Collezione Quadri Contemporary
Style L.

Tappeto Gradient.

Metropolis A06 sideboard with a
textured heat-treated oak carcass
and an anthracite 160 metal base.
W 216 D 51 H 85.5 cm

Contemporary Style L Quadri
collection.

Gradient rug.

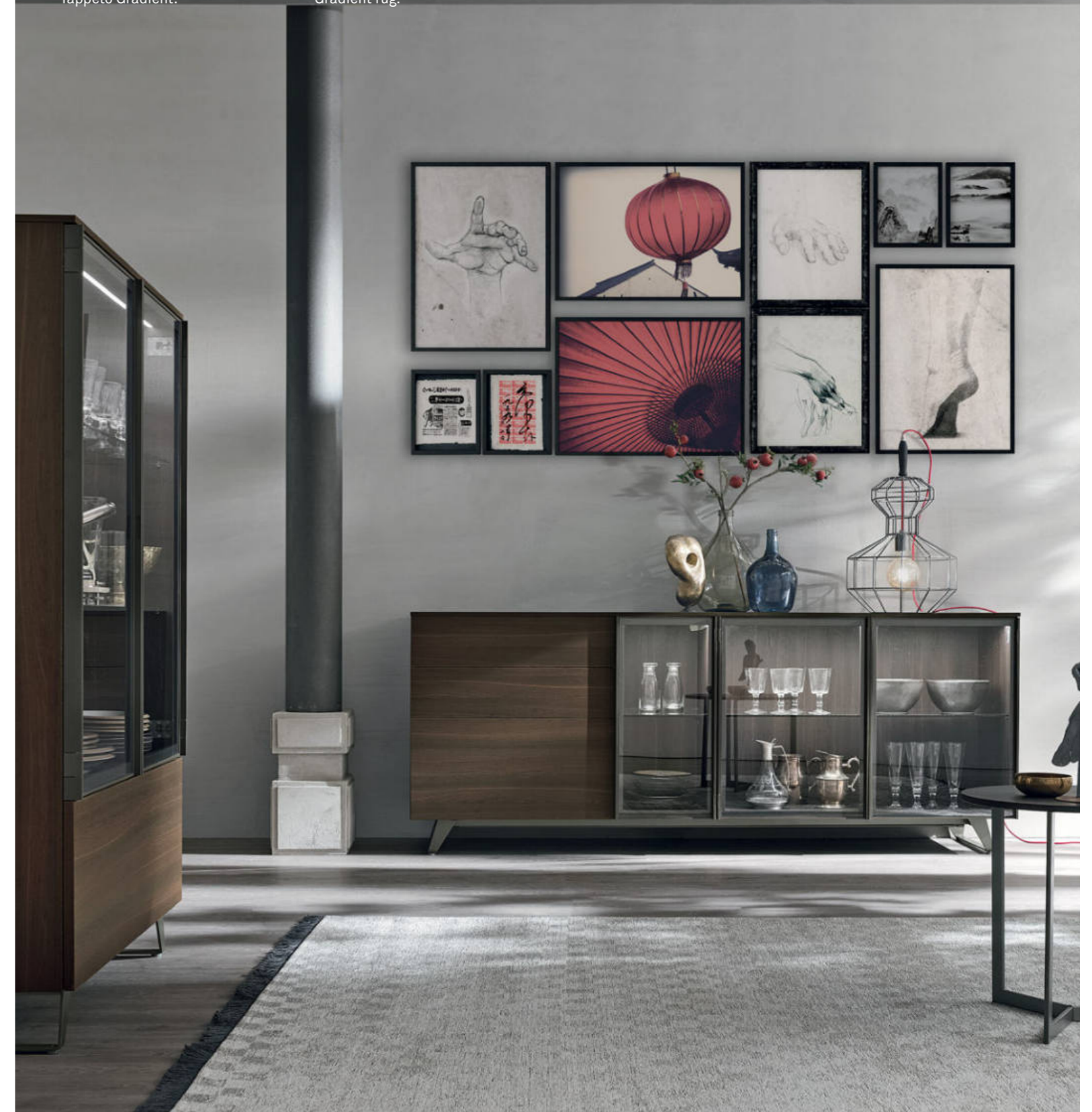



METROPOLIS

Madia Metropolis A02 struttura laccato opaco salvia 159, basamento metallo antracite 160.
L 216 P 51 H 85,5 cm

Collezione Quadri Contemporary Style S.

Metropolis A02 sideboard with a matt sage 159 lacquered carcass and an anthracite 160 metal base.

W 216 D 51 H 85.5 cm

Contemporary Style S Quadri collection.



METROPOLIS

Madia Metropolis A04 struttura
laccato opaco carta da zucchero 155,
basamento metallo antracite 160.
L 216 P 51 H 85,5 cm

Wallpaper WPT 550.

Metropolis A04 sideboard with a
matt blue grey 155 carcass and an
anthracite 160 metal base.

W 216 D 51 H 85,5 cm

WPT 550 wallpaper.

METROPOLIS

Madia Metropolis C01 materico opaco madreperla e materico frassino oriente, basamento metallo antracite 160. L 144 P 51 H 121,5 cm

Metropolis C01 sideboard in matt mother of pearl and textured eastern ash, anthracite 160 metal base. W 144 D 51 H 121.5 cm



METROPOLIS

Madia Metropolis A03 struttura laccato opaco bianco gesso 121, basamento metallo antracite 160. L 216 P 51 H 85,5 cm

Collezione Quadri Elegance Style M.

Metropolis A03 sideboard with a matt chalk white 121 lacquered carcass and anthracite 160 metal base. W 216 D 51 H 85.5 cm

Elegance Style M Quadri collection.





METROPOLIS

Madia Metropolis A01 struttura laccato opaco bianco gesso 121 e smoke 128. Basamento metallo antracite 160. L 216 P 51 H 85 cm

Tappeto Frame.

Wallpaper WPT 512.

Metropolis A01 sideboard with a matt chalk white 121 and smoke 128 carcass. Anthracite 160 metal base. W 216 D 51 H 85 cm

Frame rug.

WPT 512 wallpaper.

METROPOLIS

misure / size

P / D 51 cm

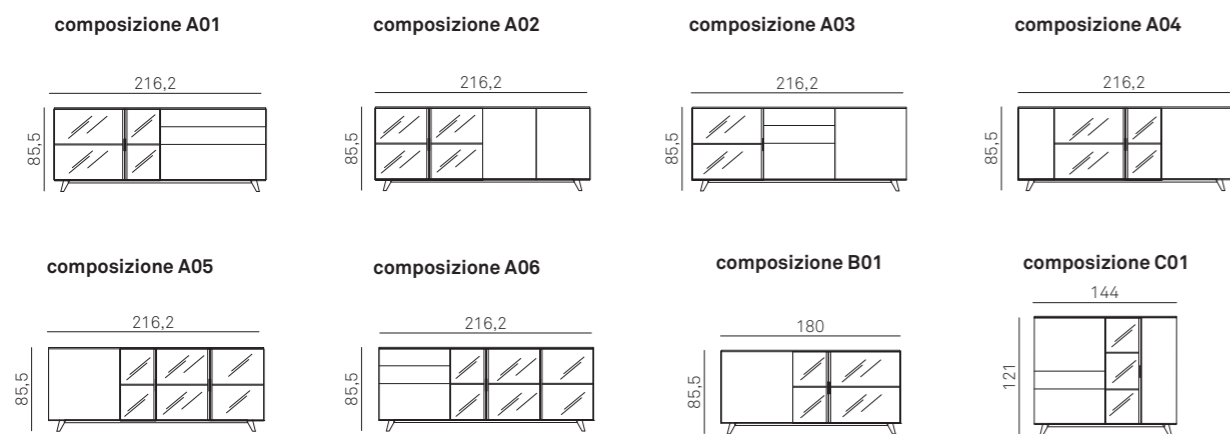

P / D 40 cm

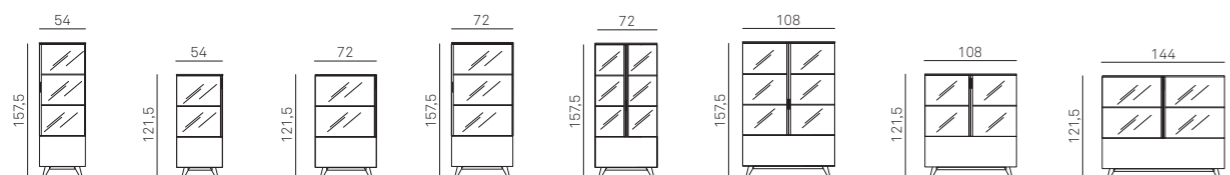

P / D 40 - 51 cm



FINITURE STRUTTURA / CARCASS FINISHES

ESSENZE / WOOD FINISHES



MATERICO ESSENZA / TEXTURED WOOD



MATERICO NODATO / KNOTTED TEXTURED

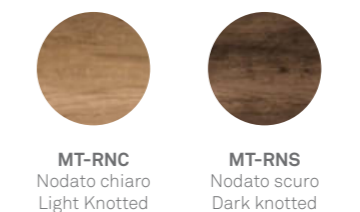

MATERICO OPACO / MATT TEXTURED

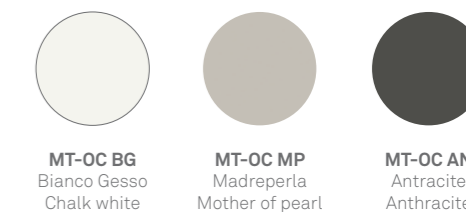

MATERICO / TEXTURED



MATERICO PORO APERTO / OPEN PORE TEXTURED



LEGNO LACCATO PORO APERTO / OPEN-PORE LACQUERED WOOD



LACCATI / LACQUERS

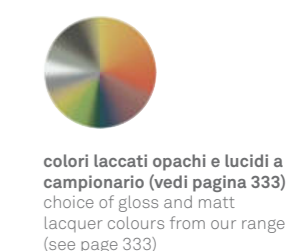

FINITURE ANTA METROPOLIS / METROPOLIS DOOR FINISHES



FINITURE BASAMENTO / BASE FINISHES

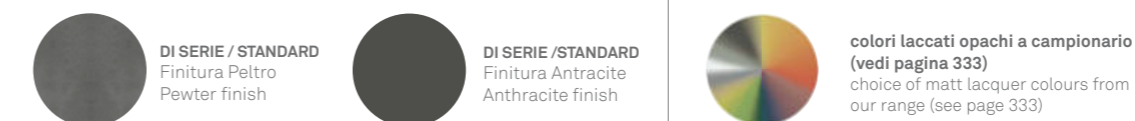





METROPOLIS

Pagina precedente
 Madia Diagonal Var. A struttura materico frassino orientale, metallo bianco gesso 121.
 L 219 P 51 H 85,5 cm

Mensole Ring materico frassino orientale, metallo bianco gesso 121.
 L 144 P 26 H 27 cm

Poltroncina Loft struttura legno frassino orientale, rivestimento cat. c linara 31.
 L 59 P 70 H 64 cm

Pouf Guccino rivestimento cat. c linara 30 e laccato opaco bianco gesso 121.
 Ø 40 H 53 cm

Tappeto Diagonal.

Preceding page
 Diagonal sideboard Var. Textured eastern ash and chalk white 121 metal carcass.
 W 219 D 51 H 85.5 cm

Ring shelves in textured eastern ash and chalk white 121 metal.
 L 144 D 26 H 27 cm

Loft armchair with an eastern ash wood frame upholstered with cat. c linara 31 fabric.
 W 59 D 70 H 64 cm

Guccino pouf upholstered with cat. c linara 30 fabric and mat chalk white 121 lacquered.
 Ø 40 H 53 cm

Diagonal rug.





DIAGONAL

Madia Diagonal Var. B struttura materico opaco bianco gesso, materico frassino oriente, metallo smoke 128.
L 219 P 51 H 85,5 cm

Poltroncina Loft struttura legno rovere termocotto, rivestimento cat. b econabuk 07.
L 59 P 70 H 64 cm

Diagonal sideboard Var. B in textured matt chalk white, textured eastern ash and smoke 128 metal.
W 219 D 51 H 85.5 cm

Loft armchair with a heat-treated oak wood frame upholstered with cat. b eco-nubuck 07.
W 59 D 70 H 64 cm

Il taglio diagonale crea un vano a giorno per mettere gli oggetti in bella vista. La madia è ricca di soluzioni pratiche per contenere ed esporre.

The diagonal cut-out creates open shelving for showcasing favourite objects. The sideboard features a wealth of practical storage and display solutions.

DIAGONAL

Madia Diagonal Var. A struttura materico rovere termocotto, vano a giorno metallo madreperla 124 e basamento metallo antracite 160.
L 219 P 51 H 85,5 cm

Sedia Lola struttura legno rovere termocotto, rivestimento cat. b ecopelle vintage 107.
L 55 P 53 H 81/47 cm

Diagonal sideboard Var. A with a textured heat-treated oak carcass, an open compartment in mother of pearl 124 metal and an anthracite 160 metal base.
W 219 D 51 H 85.5 cm

Lola chair with a heat-treated oak wood frame upholstered with cat. b vintage 107 eco-leather.
W 55 D 53 H 81/47 cm



DIAGONAL



Struttura laccato opaco madreperla 124, materico frassino oriente e vani a giorno metallo antracite 160. Matt mother of pearl 124 and textured eastern ash carcass, anthracite 160 metal open compartments.



Struttura materico rovere termocotto, vani a giorno metallo madreperla 124. Textured heat-treated oak carcass and mother of pearl 124 metal open compartments.

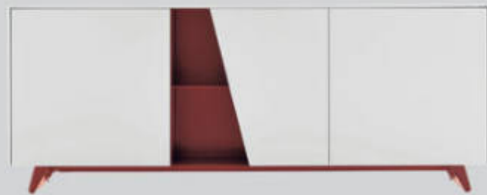

Struttura laccato opaco bianco gesso 121, vani a giorno e basamento metallo bordeaux 156. Matt chalk white 121 lacquered carcass, burgundy 156 metal open compartments and base.



Struttura laccato opaco smoke 128, vani a giorno e basamento metallo pomice 152. Matt smoke 128 lacquered carcass, pumice 152 metal open compartments and base.

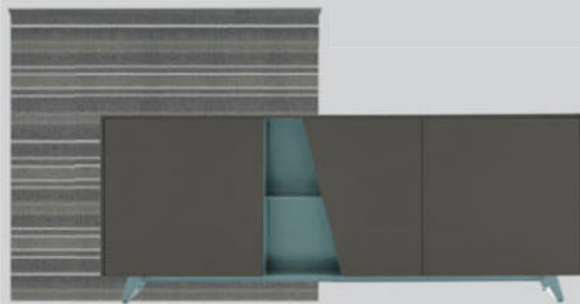

Struttura laccato opaco antracite 160, vani a giorno e basamento metallo salvia 159. Pannello Krea grafica 452. Matt anthracite 160 lacquered carcass, sage 159 metal open compartments and base. Graphic 452 Krea panel.



Struttura laccato opaco carta da zucchero 155, vani a giorno e basamento metallo antracite 160. Pannello Krea grafica 412. Matt blue grey 155 lacquered carcass, anthracite 160 metal open compartments and base. Graphic 412 Krea panel.

DIAGONAL

Madia Diagonal struttura materico opaco bianco gesso e materico nodato scuro, vani a giorno metallo antracite 160. L 183 P 51 H 111,5 cm

Diagonal sideboard with textured matt chalk white and textured dark knotted carcass. Anthracite 160 metal open compartments. W 183 D 51 H 111,5 cm





DIAGONAL

Madia Diagonal Var.B struttura materico opaco bianco gesso e materico nodato scuro. Vani a giorno e basamento metallo antracite 160.
L 219 P 51 H 85,5 cm

Pannello Krea grafica 411.
L 144 P 22 H 144 cm

Collezione Quadri Colors Style XS.

Tappeto Stripes.

Diagonal sideboard Var. B with textured matt chalk white and textured dark knotted carcass. Anthracite 160 metal open compartments and base.
W 219 D 51 H 85.5 cm

Graphic 411 Krea panel.
W 144 D 22 H 144 cm

Colors Style XS Quadri collection.

Stripes rug.

KREA

boiserie Krea / Krea wall panelling misure / size L/W 144 P/D 22 H 144 cm

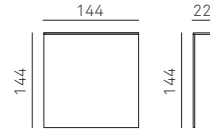

FINITURE BOISERIE / FINISHES WALL PANELLING

MATERICO ESSENZA /
WOOD TEXTURE



MT-FO
Frassino Oriente
Eastern Ash



MT-RT
Rovere termocotto
Heat-treated Oak



MT-RNC
Nodato chiaro
Light Knotted



MT-RNS
Nodato scuro
Dark knotted

MATERICO OPACO /
MATT TEXTURED



MT-OC BG
Bianco Gesso
Chalk white



MT-OC MP
Madreperla
Mother of pearl



MT-OC AN
Antracite
Anthracite

MATERICO PORO APERTO /
OPEN PORE MATERIC



MT-PA BG
Bianco Gesso
Chalk white



MT-PA MP
Madreperla
Mother of pearl

MATERICO /
TEXTURED

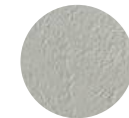

MT-CC
Cemento chiaro
Light cement



MT-CS
Cemento scuro
Dark cement

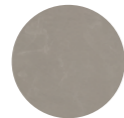

MT-CV
Cemento cava
Cava cement

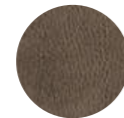

MT-MB
Maya Bronze



MT-INT C
Intreccio chiaro

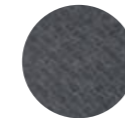

MT-INT S
Intreccio scuro

FINITURE BOISERIE E MENSOLA/
SHELF FINISHES AND WALL PANELLING
LACCATI / LACQUERS

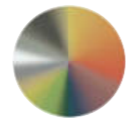

colori laccati opachi
a campionario (vedi pagina 333)
choice of matt lacquer colours
from our range (see page 333)

GRAFICHE PER BOISERIE KREA / GRAPHIC DESIGNS FOR KREA WALL PANELLING

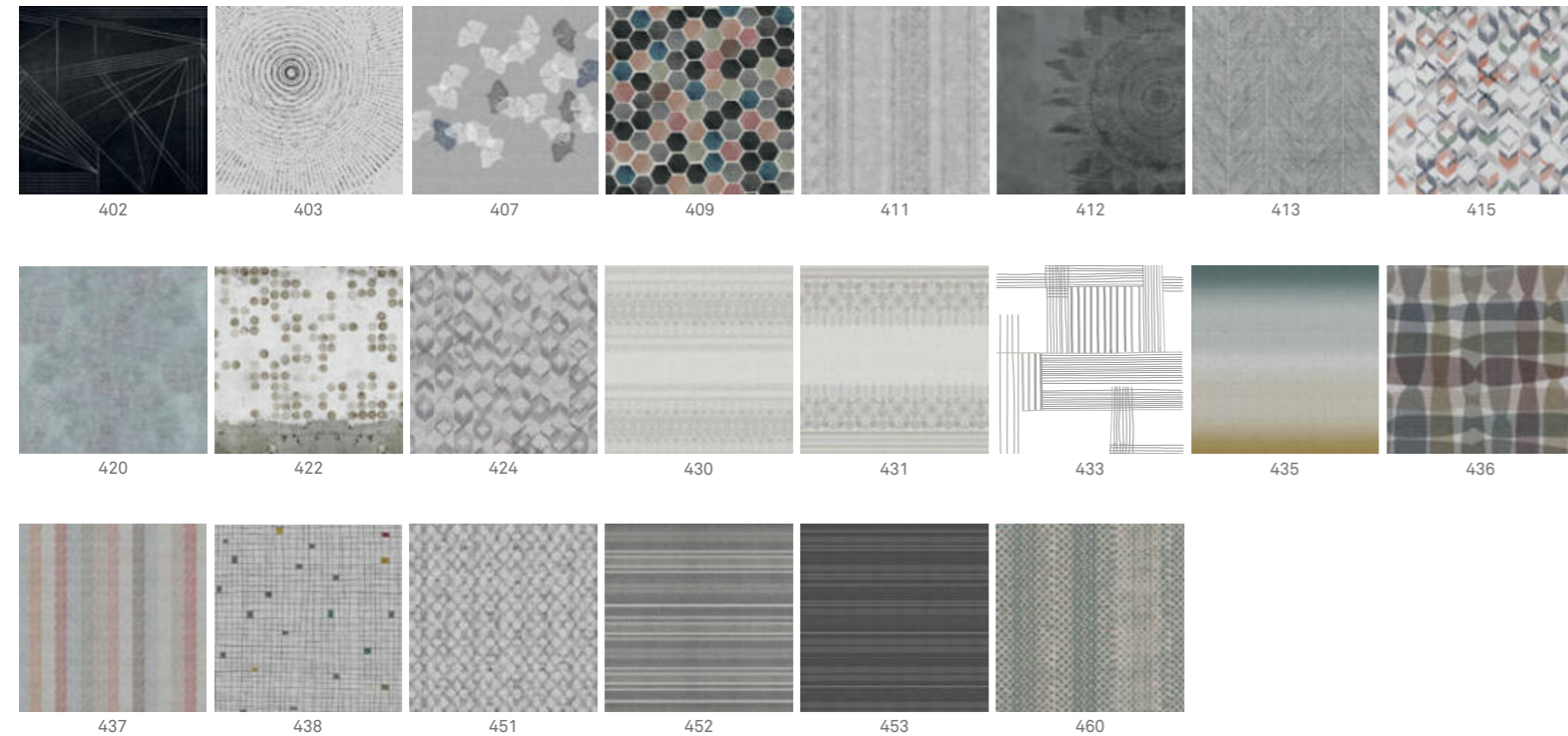

DIAGONAL

misure / size

P/D 51 cm

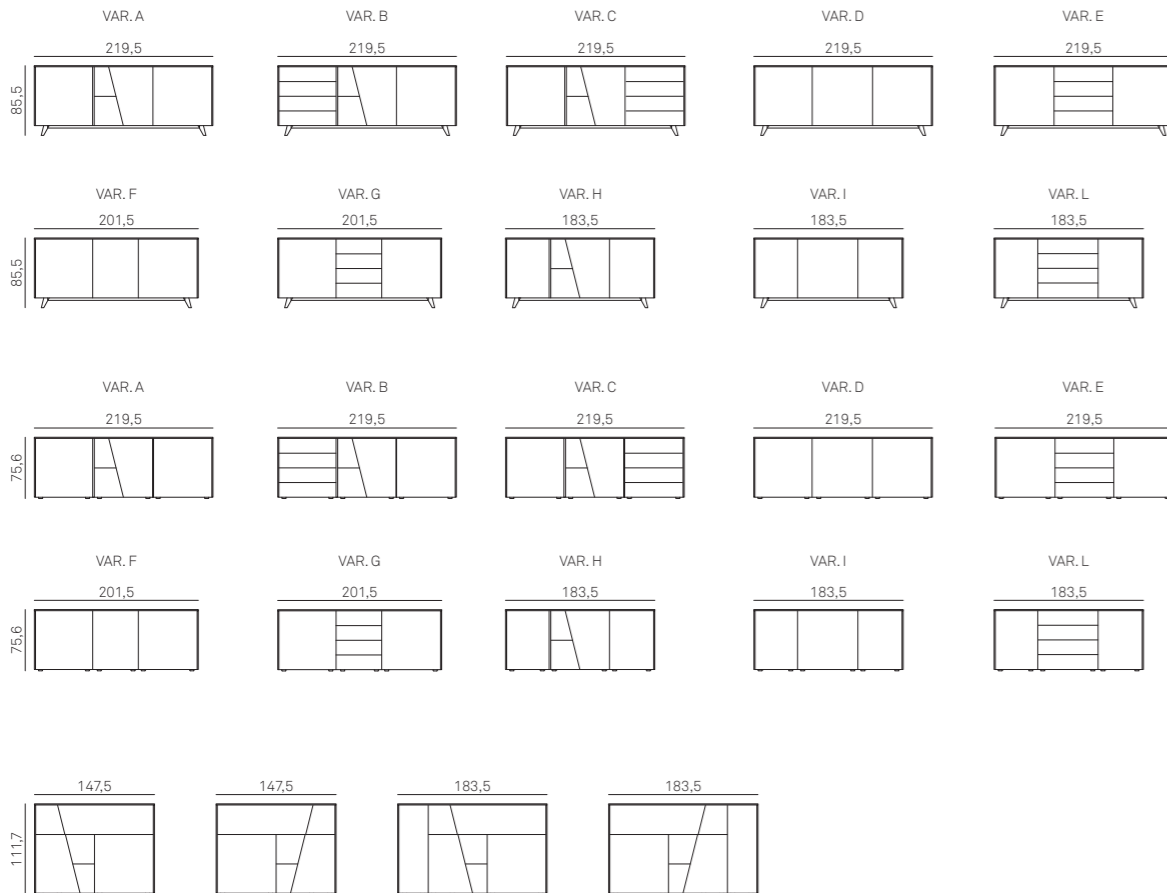

FINITURE STRUTTURA / STRUCTURE FINISHES

ESSENZE / WOOD FINISHES



LGN-FO
Frassino Oriente
Eastern Ash



LGN-RT
Rovere termocotto
Heat-treated Oak

MATERICO ESSENZA / WOOD TEXTURE



MT-FO
Frassino Oriente
Eastern Ash



MT-RT
Rovere termocotto
Heat-treated Oak

MATERICO NODATO / KNOTTED TEXTURED

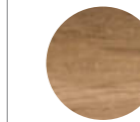

MT-RNC
Nodato chiaro
Light Knotted

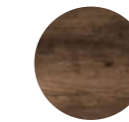

MT-RNS
Nodato scuro
Dark knotted

MATERICO OPACO / MATT TEXTURED



MT-OC BG
Bianco Gesso
Chalk white



MT-OC MP
Madreperla
Mother of pearl



MT-OC AN
Antracite
Anthracite

MATERICO PORO APERTO / OPEN PORE MATERIC



MT-PA BG
Bianco Gesso
Chalk white



MT-PA MP
Madreperla
Mother of pearl

MATERICO / TEXTURED



MT-CC
Cemento chiaro
Light cement



MT-CS
Cemento scuro
Dark cement

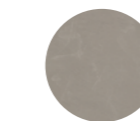

MT-CV
Cemento cava
Cava cement



MT-MB
Maya Bronze



MT-INT C
Intreccio chiaro



MT-INT S
Intreccio scuro

LACCATI / LACQUERS

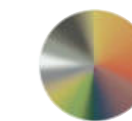

colori laccati opachi e lucidi a campionario (vedi pagina 333)
choice of matt and gloss lacquer colours from our range (see page 333)

LEGNO LACCATO PORO APERTO / OPEN-PORE LACQUERED WOOD



221 PA
Bianco Gesso
Chalk white



222 PA
Panna
Cream

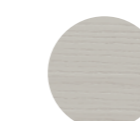

224 PA
Madreperla
Mother of pearl



227 PA
Hot
Hot grey



230 PA
Grigio Piacenza
Piacenza grey



250 PA
Canapa
Hemp

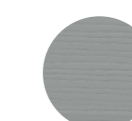

252 PA
Pomice
Pumice



260 PA
Antracite
Anthracite

FINITURE BASAMENTO E VANI A GIORNO / BASE AND OPEN UNIT FINISHES



DI SERIE / STANDARD
Finitura Peltro
Pewter finish



DI SERIE / STANDARD
Finitura Antracite
Anthracite finish



colori laccati opachi a campionario (vedi pagina 333)
choice of matt lacquer colours from our range (see page 333)

ATHENA



Madia Athena 3 ante struttura materico frassino orientale, inserti laccato opaco antracite 160 e basamento metallo antracite 160.
L 181 P 51 H 85 cm

Pensile Ciko metallo antracite 160 e specchio argentato 381.
L 36 P 24 H 36 cm

Wallpaper WPT 553.

3-door Athena sideboard with a textured eastern ash carcass, matt anthracite 160 lacquered inserts and anthracite 160 metal base.
W 181 D 51 H 85 cm

Anthracite 160 metal ciko wall unit with silver 381 mirror.
W 36 D 24 H 36 cm

WPT 553 wallpaper.



^
ATHENA

Madia Athena particolare ante struttura materico rovere termocotto, inserti mosaico marrone.

Athena sideboard: detail of the doors, textured heat-treated oak carcass, brown mosaic inserts.

ATHENA

Madia Athena 3 ante struttura materico rovere termocotto, inserti materico opaco madreperla e basamento metallo madreperla 124.
L 181 P 51 H 85 cm

Tappeto Frame.

3-door Athena sideboard with textured heat-treated oak carcass, textured matt mother or pearl inserts and mother of pearl 124 metal base.
W 181 D 51 H 85 cm

Frame rug.





ATHENA

Madia Athena 3 ante struttura laccato opaco pomice 152, inserti vetro antracite 360, basamento metallo antracite 160.
L 181 P 51 H 85 cm

3-door Athena sideboard with a matt pumice 152 lacquered carcass and anthracite 360 glass inserts. Anthracite 160 metal base.
W 181 D 51 H 85 cm

ATHENA



Struttura laccato opaco bianco gesso 121, inserti laccato opaco antracite 160, basamento metallo antracite 160.
Matt chalk white 121 lacquered carcass with matt anthracite 160 lacquered inserts. Anthracite 160 metal base.



Struttura materico frassino oriente, inserti laccato opaco antracite 160 e basamento metallo antracite 160.
Textured eastern ash carcass, matt anthracite 160 lacquered inserts and anthracite 160 metal base.



Struttura laccato opaco madreperla 124, inserti laccato opaco smoke 128, basamento metallo smoke 128.
Matt 124 mother of pearl lacquered carcass, matt smoke 128 lacquered inserts, smoke 128 metal base.



Struttura laccato opaco smoke 128, inserti laccato opaco bordeaux 156, basamento metallo bordeaux 156.
Matt 128 smoke lacquered carcass, matt burgundy 156 lacquered inserts, burgundy 156 metal base.



Struttura laccato opaco zafferano 158, inserti laccato opaco antracite 160, basamento metallo antracite 160.
Matt saffron 158 lacquered carcass, matt anthracite 160 lacquered inserts, anthracite 160 metal base.

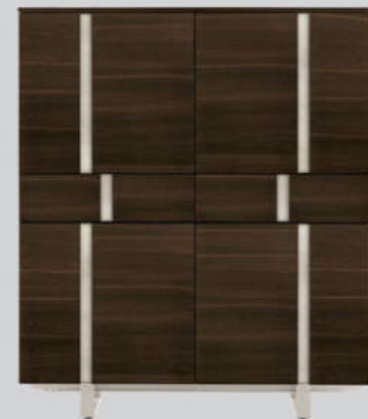

Struttura materico rovere termocotto, inserti laccato opaco madreperla 124, basamento metallo madreperla 124.
Textured heat-treated oak carcass, matt mother of pearl 124 lacquered inserts and mother of pearl 124 metal base.



ATHENA

Madia Athena 4 ante struttura laccato opaco carta da zucchero 155, inserti materico frassino oriente, basamento metallo carta da zucchero 155.
L 121 P 51 H 141 cm

Lettering City metallo antracite 160.
L 42 H 80 cm

Orologio 650.

4-door Athena sideboard with a matt blue grey 155 carcass, textured eastern ash inserts, blue grey 155 metal base.
W 121 D 51 H 141 cm

Anthracite 160 metal City Lettering.
W 42 H 80 cm

650 clock.

ATHENA

misure / size L/W 181,2 P/D 51,5 H85,4 cm L/W 120,8 P/D 51,5 H 140,7 cm

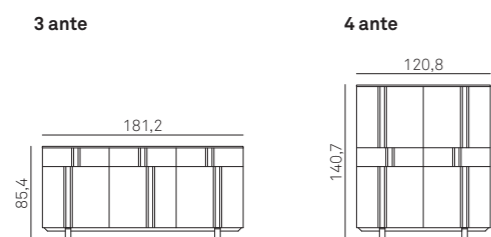

FINITURE STRUTTURA / STRUCTURE FINISHES

MATERICO ESSENZA / TEXTURED MATERIC



MATERICO OPACO / MATT MATERIC

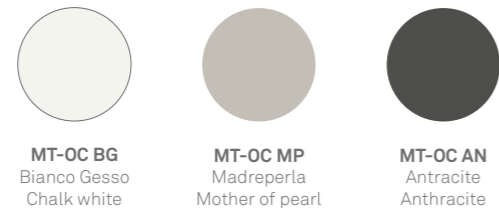

MATERICO PORO APERTO / OPEN PORE MATERIC



LEGNO LACCATO PORO APERTO / OPEN-PORE LACQUERED WOOD



LACCATI / LACQUERS

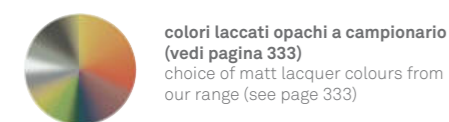

colori laccati opachi a campionario (vedi pagina 333)
choice of matt lacquer colours from our range (see page 333)

FINITURE BASAMENTO / BASE FINISHES



colori laccati opachi a campionario (vedi pagina 333)
choice of matt lacquer colours from our range (see page 333)

FINITURE GOLLA / GROOVE FINISHES

MATERICO ESSENZA / TEXTURED WOOD



MATERICO NODATO / KNOTTED TEXTURED

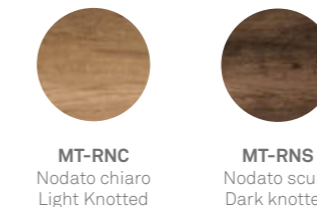

MATERICO / TEXTURED



MATERICO OPACO / MATT TEXTURED

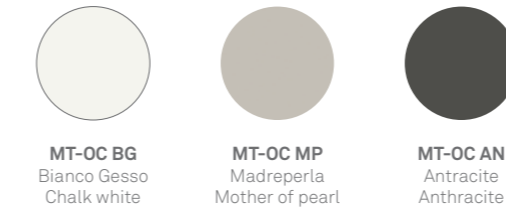

MATERICO PORO APERTO / OPEN PORE TEXTURED

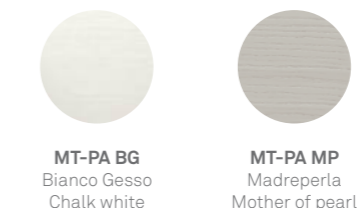

MOSAICO / MOSAIC

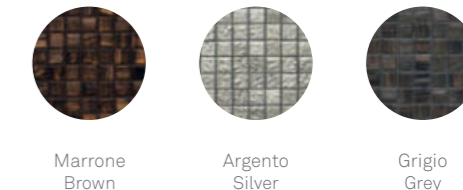

LEGNO LACCATO PORO APERTO / OPEN-PORE LACQUERED WOOD



LACCATI / LACQUERS

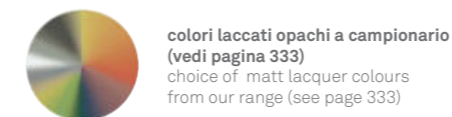

colori laccati opachi a campionario (vedi pagina 333)
choice of matt lacquer colours from our range (see page 333)

VETRO / GLASS

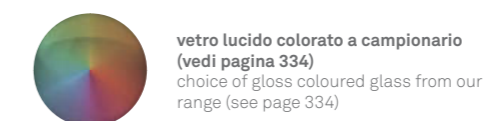

vetro lucido colorato a campionario (vedi pagina 334)
choice of gloss coloured glass from our range (see page 334)

Athena con gola laccata o in vetro colorato ha il basamento in tinta laccata colore.
Athena with coloured glass or lacquered grooves has a lacquered base in a matching colour.



Madia Madison struttura laccato opaco
antracite 160.
L 207 P 49 H 76 cm

Tavolino 33 versione 13.
Ø 40 H 38 cm

Madison sideboard with a matt
anthracite 160 lacquered carcass.
W 207 D 49 H 76 cm

33 coffee table, version 13.
Ø 40 H 38 cm



Madison con lama luminosa RGB spessore 20 mm.
Madison with 20mm-thick illuminated RGB blade.

MADISON

Madia Madison struttura laccato opaco bianco gesso 121.
L 207 P 49 H 76 cm

Pensile Ciko metallo antracite 160, grafica 260, 235, e laccato opaco salvia 159.
L 36 P 24 H 36 cm

Orologio 630.

Madison sideboard with a matt anthracite chalk white 121 lacquered carcass.
W 207 D 49 H 76 cm

Anthracite 160 and graphic 260, 235 metal and matt sage 159 lacquered Ciko wall unit.
W 36 D 24 H 36 cm

630 clock.

MADISON

misure / size L/W 206,8 P/D 48,5 H 75,9 cm

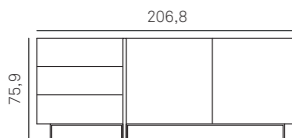

FINITURE STRUTTURA / STRUCTURE FINISHES

LACCATI / LACQUERS

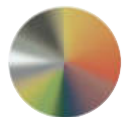

colori laccati opachi a campionario
(vedi pagina 333)
choice of matt lacquer colours from
our range (see page 333)



Madia Atlante laccato opaco smoke 128 e specchio grigio satinato 383.
L 240 P 54 H 76 cm

Sedia Lolita struttura rovere termocotto,
rivestimento cat. b hugo 04.
L 51 P 56 H 79/47 cm

Matt smoke 128 lacquered Atlante sideboard with a satin grey 383 mirror.
W 240 D 54 H 74 cm

Lolita chair with a heat-treated oak frame upholstered with cat. b hugo 04.
W 51 D 56 H 79/47 cm

ATLANTE

misure / size L/W 192 P/D 54 H 76 cm L/W 192 P/D 54 H 96 cm
L/W 240 P/D 54 H 76 cm L/W 240 P/D 54 H 96 cm

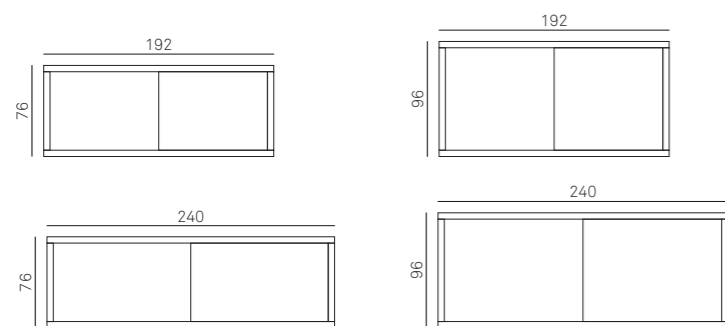

FINITURE STRUTTURA / CARCASS FINISHES

LEGNO LACCATO PORO APERTO / OPEN-PORE LACQUERED WOOD

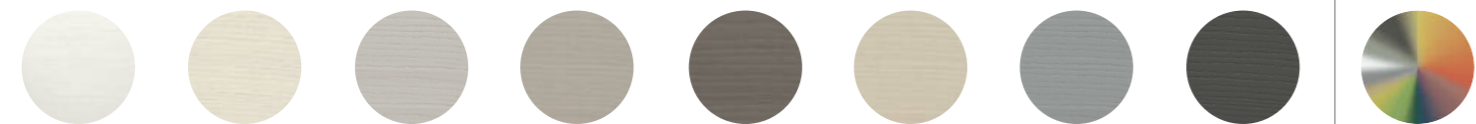

221 PA
Bianco Gesso
Chalk white

222 PA
Panna
Cream

224 PA
Madreperla
Mother of pearl

227 PA
Hot
Hot grey

230 PA
Grigio Piacenza
Piacenza grey

250 PA
Canapa
Hemp

252 PA
Pomice
Pumice

260 PA
Antracite
Anthracite

colori laccati lucidi e opachi a campionario (vedi pagina 333)
choice of gloss and matt lacquer colours from our range (see page 333)

FINITURE ANTA / DOOR FINISHES

LEGNO LACCATO PORO APERTO / OPEN-PORE LACQUERED WOOD

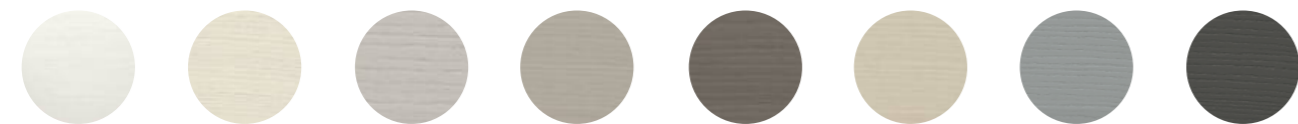

221 PA
Bianco Gesso
Chalk white

222 PA
Panna
Cream

224 PA
Madreperla
Mother of pearl

227 PA
Hot
Hot grey

230 PA
Grigio Piacenza
Piacenza grey

250 PA
Canapa
Hemp

252 PA
Pomice
Pumice

260 PA
Antracite
Anthracite

vetro lucido colorato a campionario (vedi pagina 334)
choice of gloss coloured glass from our range (see page 334)

Specchio grigio satinato 393
Satin grey mirror 393

Specchio grigio 383
Grey mirror 383

colori laccati lucidi e opachi a campionario (vedi pagina 333)
choice of gloss and matt lacquer colours from our range (see page 333)

ATLANTE

Madia Atlante legno laccato poro aperto hot 127 e specchio grigio satinato 393.
L 192 P 54 H 76 cm

Tappeto Frame.

Atlante sideboard in open-pore hot grey 127 lacquered wood with a satin grey 393 mirror.
W 192 D 54 H 76 cm

Frame rug.



poltrone e pouf

armchairs and poufs

Lasciarsi avvolgere dal design per sprofondare nella comodità: poltrone e pouf creano piccole oasi di benessere e angoli di assoluto relax all'interno di ogni stanza.

Sink into the embrace of design at its comfortable best: armchairs, ottomans and floor cushions create little havens of wellbeing and chill-out corners in each room for switching off and unwinding.



Poltroncina Loft struttura legno rovere termocotto,
rivestimento cat. b joy.
L 59 P 70 H 64 cm

Divanetto Loft struttura legno rovere termocotto,
rivestimento cat. b econabuk 5.
L 124 P 75 H 70 cm

Tavolino Caruso piano laccato opaco bianco gesso
121, basamento metallo antracite 160.
L 44 P 44 H 43 cm

Loft armchair with a heat-treated oak wood frame
upholstered with cat. b joy fabric.
W 59 D 70 H 64 cm

Loft 2-seater sofa with a heat-treated oak wood
frame upholstered with cat. b eco-nubuck 5.
W 124 D 75 H 70 cm

Caruso coffee table with matt chalk white 121
lacquered top and anthracite 160 metal base.
W 44 D 44 H 43 cm



LOFT

Poltroncina Loft struttura legno rovere termocotto, rivestimento cat. b econabuk 5. L 59 P 70 H 64 cm

Tavolino Brigitte laccato opaco antracite 160 e metallo antracite 160. Ø 45 H 52 cm

Loft armchair with a heat-treated oak wood frame upholstered with cat. b eco-nubuck 5. W 59 D 70 H 64 cm

Brigitte coffee table in matt anthracite 160 lacquer and anthracite 160 metal. Ø 45 H 52 cm

Loft poltroncina o divanetto:
per interni cosmopoliti.

Loft armchair or 2-seater sofa:
designed for cosmopolitan interiors.

LOFT

misure / size **poltrona / occasional chair:** L/W 65 P/D 75 H 70 cm
divanetto / sofa: L/W 124 P/D 75 H 70 cm
mignon: L/W 59 P/D 70 H 64 cm

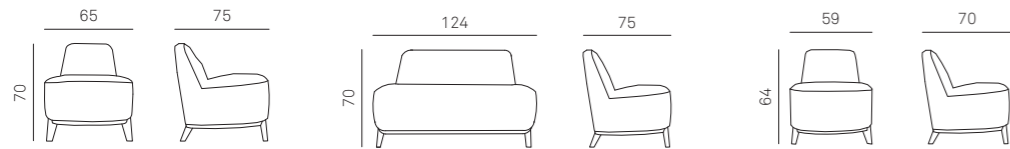

FINITURE STRUTTURA / FRAME FINISHES

ESSENZE / WOOD FINISHES



LGN-FO
Frassino Oriente
Eastern Ash



LGN-RT
Rovere Termocotto
Heat-treated Oak

RIVESTIMENTO / COVERING

Econabuk, ecopelle e pelle
Eco-nubuck, eco-leather and leather upholstery



Tessuti del campionario
Our range of fabrics



LOFT

Divanetto Loft struttura legno
frassino oriente, rivestimento
cat. b econabuk 5.
L 124 P 75 H 70 cm
Wallpaper WPT 535.

Loft 2-seater sofa with an
eastern ash wood frame
upholstered with cat. b
eco-nubuck 5.
W 124 D 75 H 70 cm
WPT 535 wallpaper.



FLOWER

Poltrona Flower
01. cat. 1/one easy 20, filo 3426.
02. cat. 1/one easy 18, filo 877.
03. cat. 1/one point 16, filo 0856.
L 85 P 75 H 75/40 cm

Flower armchair
01. cat. 1/one easy 20, yarn 3426.
02. cat. 1/one easy 20, yarn 877.
03. cat. 1/one point 16, yarn 0856.
W 85 D 75 H 75/40 cm

NEW
YORK
ROME
LONDON
PARIS
PICCOLI
LIVELLI
NEW



01.

02.

03.

FLOWER



cat. b ecopelle vintage 106.
cat. b vintage 106 eco-leather.



cat. b ecopelle vintage 106.
cat. b vintage 106 eco-leather.



cat. b ecopelle vintage 106, cat. c lino froissé 022.
cat. b vintage 106 eco-leather, cat. c froissé linen 022.



cat. b ecopelle vintage 106, cat. c lino froissé 022.
cat. b vintage 106 eco-leather, cat. c froissé linen 022.



cat. b ecopelle vintage 106, cat. c lino froissé 022.
cat. b vintage 106 eco-leather, cat. c froissé linen 022.

misure / size

poltrona / occasional chair: L/W 85 P/D 75 H 75 cm
pouff / ottoman: L/W 65 P/D 65 H 40 cm

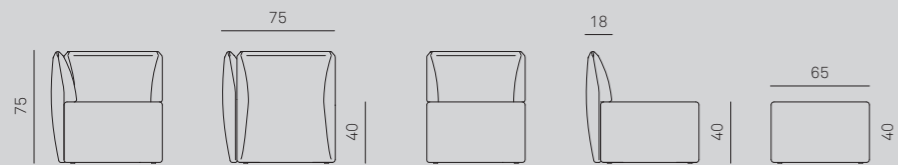

RIVESTIMENTO / COVERING

Econabuk, ecopelle e pelle
Eco-nubuck, eco-leather and leather upholstery



Tessuti del campionario
Our range of fabrics



tagliacuci (escluso per rivestimento in pelle)
piping (except for leather upholstery)



FLOWER

Poltrona Flower cat. f pelle vintage 102.
L 85 P 75 H 75/40 cm

Tavolino Joy Decor piano grafica 150, basamento metallo antracite 160.
Ø 45 H 46 cm

Wallpaper WPT550.

Flower armchair upholstered with cat. f vintage 102 leather.
W 85 D 75 H 75/40 cm

Joy Decor coffee table with graphic 150 top, anthracite 160 metal base.
Ø 45 H 46 cm

WPT550 wallpaper.

SOFT

Poltroncina Soft
01. cat. d lino froissé 123.
02. cat. d lino froissé 05.
03. cat. d lino froissé 100.
04. cat. d lino froissé 116.
L 66 P 95 H 72/41 cm

Tavolino Joy piano
materico nodato chiaro,
basamento metallo antracite 160.
Ø 60 H 38 cm

Tappeto Frame.

Soft armchair
01. cat. d froissé linen 123.
02. cat. d froissé linen 05.
03. cat. d froissé linen 100.
04. cat. d froissé linen 116.
W 66 D 95 H 72/41 cm

Joy coffee table with textured light knotted
top, anthracite 160 metal base.
Ø 60 H 38 cm

Frame rug.



01.

02.

03.

04.

Un mondo di quiete.
Una poltrona comoda e accomodante, per interiors e spazi dove liberare la mente e rilassarsi in tutta tranquillità.

A world of peaceful calm.
A comfortable and casually relaxed chair for interiors and spaces where you can tune out the world and unwind in peace.

SOFT

misure / size **poltrona / occasional chair:** L/W 66 P/W 95 H 72/41 **pouff / ottoman:** L/W 66 P/D 66 H 41 cm

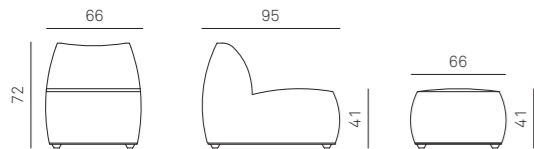

RIVESTIMENTO / COVERING

Econabuk, ecopelle e pelle
Eco-nubuck, eco-leather and leather upholstery



Tessuti del campionario
Our range of fabrics



Poltroncina Soft cat. d lino froissé 011.
L 66 P 95 H 72/41 cm

Tavolino Joy Decor piano grafica 111,
basamento metallo zafferano 158.
Ø 45 H 46 cm

Soft armchair upholstered with cat. d
froissé linen 011.
W 66 D 95 H 72/41 cm

Joy Decor coffee table with graphic 111
top, saffron 158 metal base.
Ø 45 H 46 cm

Poltrona Maya cat. b ecopelle vintage 101 e cat. d linara 13. L 72 P 84 H 79/43 cm

Tavolino Caruso metallo bianco gesso 121. L 44 P 44 H 43 cm

Panketta materico nodato chiaro, struttura metallo antracite 160. L 216 P 38 H 45 cm

Raster metallo bianco gesso 121 e materico nodato chiaro. L 144 P 30 H 18 cm

Plaid Cuzco.

Wallpaper WPT527.

Maya chair upholstered with cat. b vintage 101 eco-leather and cat. d linara 13 fabric. W 72 D 84 H 79/43 cm

Caruso coffee table in matt chalk white 121 metal. L 44 W 44 H 43 cm

Textured light knotted Panketta bench with anthracite 160 metal frame. L 216 W 38 H 45 cm

Chalk white 121 metal and textured light knotted Raster unit. W 144 D 30 H 18 cm

Cuzco throw.

WPT527 wallpaper.

MAYA

Poltroncina Maya,
doppia imbottitura con cuscino.

—

Maya armchair:
double upholstery with cushion.

MAYA

misure / size L/W 72 P/D 84 H 79/43 cm

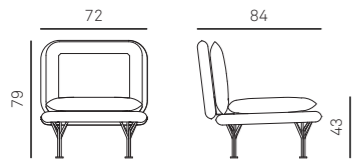

FINITURA PIEDI / FEET FINISHES

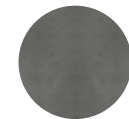

Finitura Peltro
Pewter finish

RIVESTIMENTO STRUTTURA IMBOTTITA / PADDED UPHOLSTERY ON FRAME

Econabuk, ecopelle e pelle
Eco-nubuck, eco-leather
and leather upholstery



Tessuti del campionario
Our range of fabrics



RIVESTIMENTO SEDUTA E SCHIENALE / SEAT AND BACKREST FINISHES

Econabuk, ecopelle e pelle
Eco-nubuck, eco-leather
and leather upholstery



Tessuti del campionario
Our range of fabrics



Poltrona Maya cat. b ecopelle
vintage 107, cat.1/one easy 21.
L 72 P 84 H 79/43
Tavolino Brigitte laccato opaco
antracite 160.
Ø 45 H 52 cm

Maya chair upholstered with cat. b
vintage 107 eco-leather and cat. 1/
one easy 21 fabric.
W 72 D 84 H 79/43
Brigitte coffee table in matt
anthracite 160 lacquer.
Ø 45 H 52 cm

Un senso di protezione.

A dettare lo stile della poltrona è soprattutto il design dello schienale alto che, in pelle, ecopelle, econabuk o tessuto, è avvolgente come un abbraccio.

A sense of protection.

The armchair's style is dictated, above all, by the design of its high back, which is upholstered in leather, eco-leather, eco-nubuck or fabric and wraps round the occupant in a hug.

VANESSA

misure / size L/W 64 P/D 64 H 90/50 cm

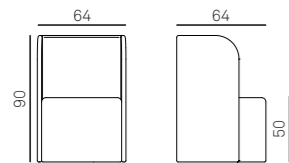

RIVESTIMENTO / COVERING

Econabuk, ecopelle e pelle
Eco-nubuck, eco-leather and leather upholstery



Tessuti del campionario
Our range of fabrics



VANESSA

Poltroncina Vanessa
cat. c lino froissé 011.
L 64 P 64 H 90/50 cm

Tavolino Caruso laccato
opaco bianco gesso 121.
L 44 P 44 H 43 cm

Plaid Lino sacco.
L 150 P 195 cm

Vanessa armchair
upholstered with oat. c
froissé linen 011 fabric.
W 64 D 64 H 90/50 cm

Caruso coffee table in matt
chalk white 121 lacquer.
L 44 W 44 H 43 cm

Lino Sacco throw.
L 150 W 195 cm

Comodità al femminile.
Le cuciture attraversano lo schienale imbottito e lo valorizzano.
L'amore per il dettaglio e la cura sartoriale si siedono qui.

Comfort shows its feminine side.
Stitching runs across the padded back for added luxury.
A love of detail and skilful tailoring sit happily side by side.

LINDA

misure / size L/W 67 P/D 67 H 75 cm

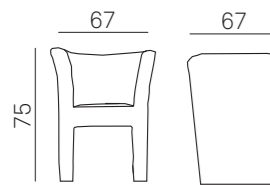

RIVESTIMENTO / COVERING

Econabuk, ecopelle e pelle
Eco-nubuck, eco-leather and leather upholstery





Informali, originali, morbidi e scanzonati, i pouf danno nuove forme alla convivialità. Quasi mai da soli, in compagnia danno il meglio di sé.

Casual, original, soft and easygoing, ottomans add a new twist to any hang-out zone. Rarely solitary, they really come into their own when they're in company.



Cookie pouf con rivestimento in vari tessuti.

Cookie ottomans covered in various fabrics.



COOKIE

misure / size L/W 47 P/D 47 H 46 cm

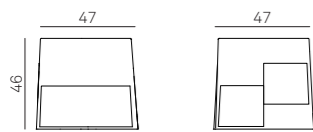

RIVESTIMENTO / COVERING

Econabuk, ecopelle e pelle
Eco-nubuck, eco-leather and leather upholstery



Tessuti del campionario
Our range of fabrics



tagliacuci (escluso per rivestimento in pelle)
piping (except for leather upholstery)





Giglio 01.
cat. 1/one point 28, cat. b ecopelle vintage 107.
cat. 1/one point 28, cat. b vintage 107 eco-leather.

Giglio 02.
cat. c lino froissè 006, cat. b ecopelle vintage 103.
cat. c froissè linen 006, cat. b vintage 103 eco-leather.

Giglio 03.
cat. 1/one point 01, cat. b ecopelle vintage 103.
cat. 1/one point 01, cat. b vintage 103 eco-leather.

Giglio 04.
cat. c lino froissè 015, cat. b ecopelle vintage 102.
cat. c froissè linen 015, cat. b vintage 102 eco-leather.

Giglio 05.
cat. 1/one point 16, cat. b ecopelle vintage 106.
cat. 1/one point 16, cat. b vintage 106 eco-leather.

GIGLIO

misure / size L/W 85 P/D 85 H 30 cm

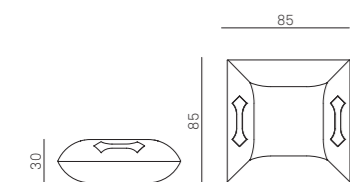

RIVESTIMENTO / COVERING

Tessuti del campionario
Our range of fabrics



INSERTO E MANIGLIE / INSERT AND HANDLES

Ecopelle Vintage
Vintage eco-leather



Giglio 06.
cat. 1/one point 01, cat. b ecopelle vintage 102.
cat. 1/one point 01, cat. b vintage 102 eco-leather.

Giglio 07.
cat. 1/one point 28, cat. b ecopelle vintage 107.
cat. 1/one point 28, cat. b vintage 107 eco-leather.

Giglio 08.
cat. 1/one point 11, cat. b ecopelle vintage 103.
cat. 1/one point 11, cat. b vintage 103 eco-leather.

Giglio 09.
cat. 1/one point 06, cat. b ecopelle vintage 103.
cat. 1/one point 06, cat. b vintage 103 eco-leather.



Pouf Guccino
 laccato opaco madreperla
 124, cat. c linara 16.
 laccato opaco madreperla
 124, cat. c linara 03.
 Ø 40 H 53 cm

Guccino pouf
 matt mother of pearl 124
 lacquered, cat. c linara 16.
 matt mother of pearl 124
 lacquered, cat. c linara 03.
 Ø 40 H 53 cm



GUCCINO

GUCCINO

misure / size Ø 40 H 53 cm

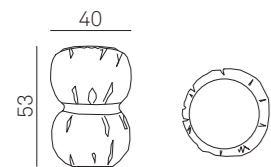

FINITURA TOP / TOP FINISHES

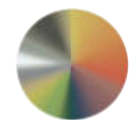

colori laccati opachi a campionario
 (vedi pagina 333)
 choice of matt lacquer colours
 from our range (see page 333)

RIVESTIMENTO / COVERING

Econabuk, ecopelle e pelle
 Eco-nubuck, eco-leather and
 leather upholstery



Tessuti del campionario
 Our range of fabrics



COMODO

misure / size L 85 P 85 H 85 cm

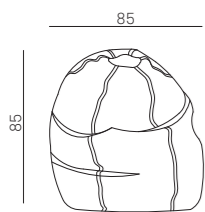

Comodo 01.
cat. 1/one easy 18, filo 877.
cat. 1/one easy 18, yarn 877.

Comodo 02.
cat. c lino froissè 100 e 033, filo 877.
cat. c froissè linen 100 and 033 fabric,
yarn 877.

Comodo 03.
cat. b ecopelle vintage 107, filo 877.
cat. b vintage 107 eco-leather, yarn
877.

Comodo 04.
cat. b texas 28, filo 877.
cat. b texas 28, yarn 877.

Comodo 05.
cat. b texas 31 e 12, filo 877.
cat. b texas 31 and 12, yarn 877.

Comodo 06.
cat. 1/one easy 20, filo 3426.
cat. 1/one easy 20, yarn 3426.
L 85 P 85 H 85 cm

Libreria Movida struttura metallo
bianco gesso 121, ripiani materico
nodato chiaro.
L 74 P 38 H 190 cm

Movida bookcase with chalk white 121
metal frame and textured light knotted
shelves.
W 74 D 38 H 190 cm

Tappeto Gradient.
Gradient rug.



COMODO

tavolini

coffee tables

Utili in ogni situazione, perfetti in tutte le stanze, piccoli luoghi di incontro o pratici piani di appoggio, i tavolini sono molto funzionali e affiancano divani, sedute o letti con la varietà delle loro forme.

Handy whatever the situation, perfect in any room, providing a focal point for little get-togethers or practical set-down space, coffee and side tables are highly functional and their myriad shapes make them a perfect companion for sofas, seating or beds.



Tavolino Joy

- 01. piano materico cemento chiaro, struttura metallo peltro. Ø 100 H 26 cm
- 02. piano materico nodato scuro, struttura metallo peltro. Ø 60 H 39 cm
- 03. piano laccato opaco bianco gesso 121, struttura metallo peltro. Ø 100 H 26 cm
- 04. piano materico cemento scuro, struttura metallo peltro. Ø 60 H 39 cm
- 05. piano materico nodato chiaro, struttura metallo bianco gesso 121. Ø 100 H 26 cm
- 06. piano laccato opaco bianco gesso 121, struttura metallo bianco gesso 121. Ø 100 H 26 cm

Joy coffee table.

- 01. textured light cement top, pewter metal frame. Ø 100 H 26 cm
- 02. textured dark knotted top, pewter metal frame. Ø 60 H 39 cm
- 03. chalk white 121 lacquered top, pewter metal frame. Ø 100 H 26 cm
- 04. textured dark cement top, pewter metal frame. Ø 60 H 39 cm
- 05. textured light knotted top, chalk white 121 metal frame. Ø 100 H 26 cm
- 06. chalk white 121 lacquered top, chalk white 121 metal frame. Ø 100 H 26 cm

JOY



JOY

misure / size Ø 45 H 47cm Ø 60 H 39 cm Ø 100 H 26 cm

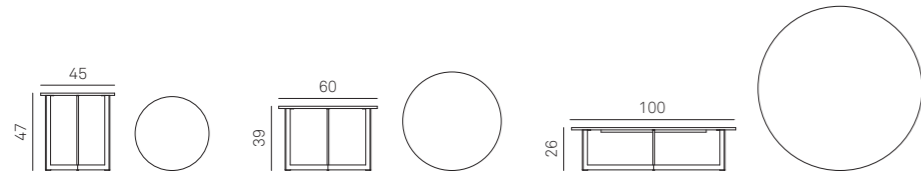

FINITURE BASAMENTO / BASE FINISHES

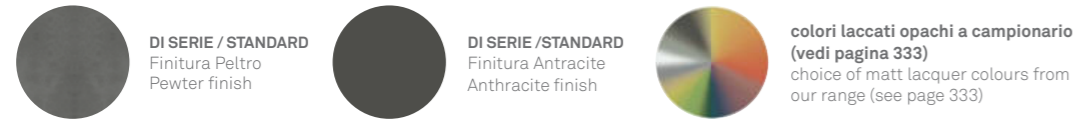

FINITURE PIANO / TOP FINISHES

MATERICO ESSENZA / TEXTURED WOOD



MATERICO NODATO / KNOTTED TEXTURED

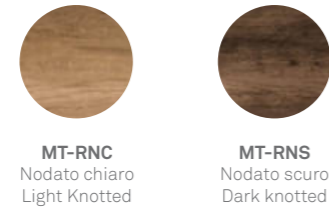

MATERICO OPACO / MATT MATERIC

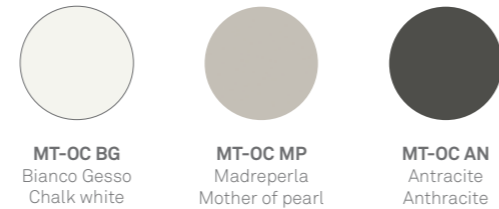

MATERICO / TEXTURED



MATERICO PORO APERTO / OPEN PORE MATERIC



LEGNO LACCATO PORO APERTO / OPEN-PORE LACQUERED WOOD



HPL

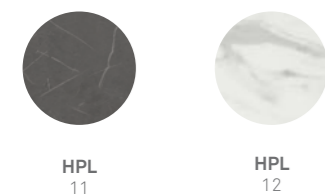

LACCATI / LACQUERS

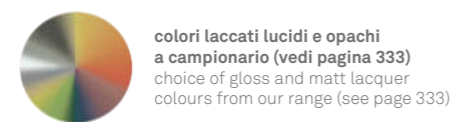

Tavolino Joy
01. piano materico cemento chiaro, struttura metallo antracite 160. Ø 100 H 26 cm

02. piano materico nodato chiaro, struttura metallo antracite 160. Ø 60 H 39 cm

03. piano materico cemento scuro, struttura metallo antracite 160. Ø 45 H 47 cm

Tappeto Gradient.

Joy coffee table
01. textured light cement top, anthracite 160 metal frame. Ø 100 H 26 cm

02. textured light knotted top, anthracite 160 metal frame. Ø 60 H 39 cm

03. textured dark cement top, anthracite 160 metal frame. Ø 45 H 47 cm

Gradient rug.

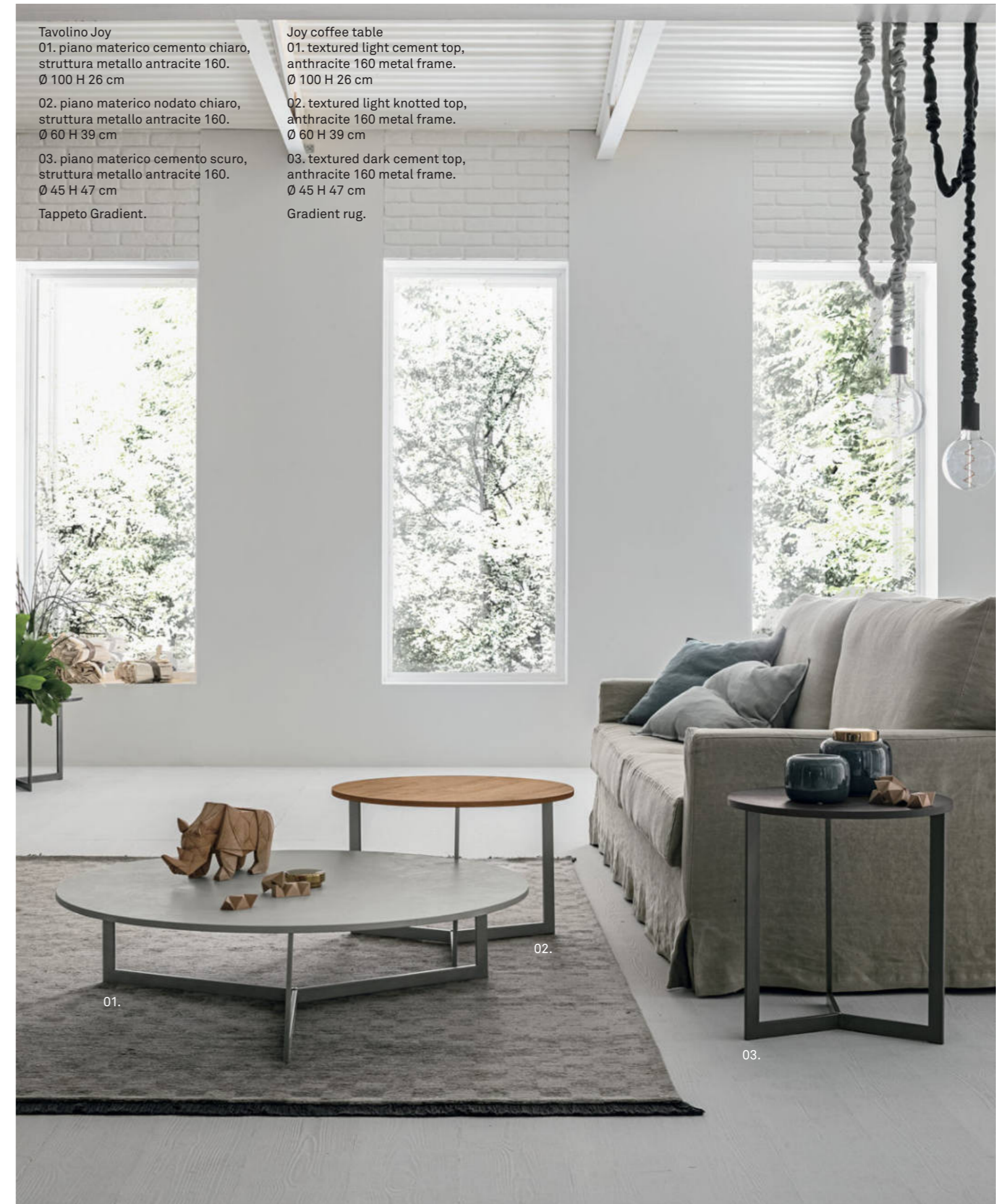

JOY DECOR

misure / size Ø 45 H 46 cm Ø 60 H 38 cm Ø 100 H 25 cm (no grafica)



FINITURE BASAMENTO / BASE FINISHES

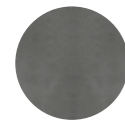

DI SERIE / STANDARD
Finitura Peltro
Pewter finish



DI SERIE / STANDARD
Finitura Antracite
Anthracite finish



colori laccati opachi a campionario
(vedi pagina 333)
choice of matt lacquer colours from
our range (see page 333)

GRAFICHE TOP / TOP GRAPHIC



102

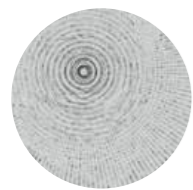

103

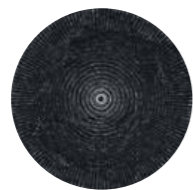

104

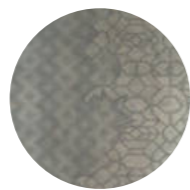

105

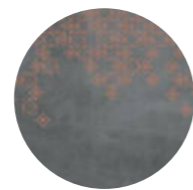

106

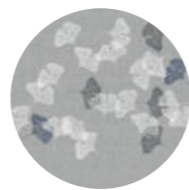

107



108

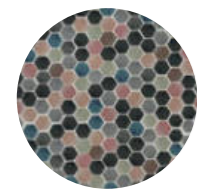

109

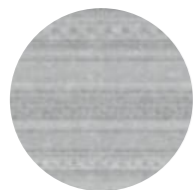

111



112



113

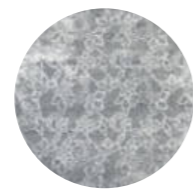

116

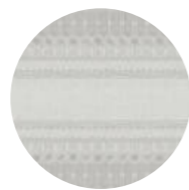

130

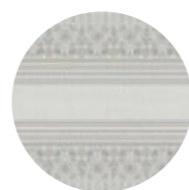

131

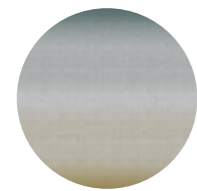

135

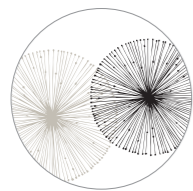

138

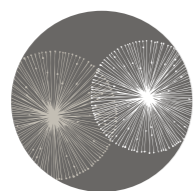

139



150

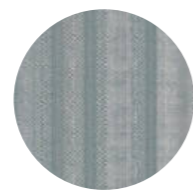

160



JOY DECOR

Tavolino Joy decor vari colori di struttura e 19 diverse grafiche creative per il top.

Joy decor coffee table in various frame colours and 19 different creative graphic designs for the top.

Tavolino Wood:
la natura nel tuo salotto.

Wood coffee table:
nature in your living room.

JOY WOOD

misure / size Ø 45 H 46 cm Ø 60 H 38 cm

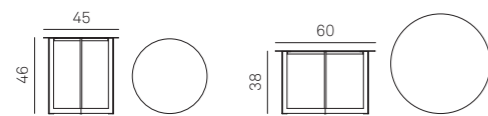

FINITURE TOP / TOP FINISHES



Noce Canaletto
Black walnut
Ø 45



Rovere
Oak
Ø 60

FINITURE BASAMENTO / BASE FINISHES



DI SERIE / STANDARD
Finitura Peltro
Pewter finish



DI SERIE / STANDARD
Finitura Antracite
Anthracite finish



colori laccati opachi a campionario
(vedi pagina 333)
choice of matt lacquer colours from
our range (see page 333)



01.

Tavolino Joy Wood
01. piano legno rovere, struttura metallo
bianco gesso 121.
Ø 60 H 38 cm

02. piano legno noce canaletto, struttura
metallo antracite 160.
Ø 45 H 46 cm

02.

Joy Wood coffee table
01. oak wood top, chalk white 121 metal
frame.
Ø 60 H 38 cm

02. black walnut wood top, anthracite 160
metal frame.
Ø 45 H 46 cm

La forma è tutto.
Una sagoma irregolare per un tavolino dallo spirito moderno.
Leggero nelle linee ma allo stesso tempo forte nel design.

Form is everything.
An irregular shape for a modern-minded side table.
Light in its lines yet strong in design.

CARUSO

misure / size L/W 44,5 cm P/D 44 cm H 43,1 cm

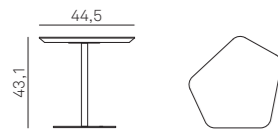

FINITURA PIANO / TOP FINISHES

LACCATI / LACQUERS

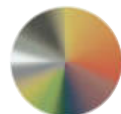

colori laccati opachi a campionario
(vedi pagina 333)
choice of matt lacquer colours from
our range (see page 333)

FINITURA BASAMENTO / BASE FINISHES



DI SERIE / STANDARD
Laccato bianco gesso
Chalk white lacquered

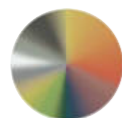

colori laccati opachi a campionario
(vedi pagina 333)
choice of matt lacquer colours
from our range (see page 333)



CARUSO

Tavolino Caruso
01. laccato opaco pomice 152.
02. laccato opaco bianco gesso 121.
L 44,5 P 44 H 43,1 cm

Caruso coffee table
01. matt pumice 152 lacquer.
02. matt chalk white 121 lacquer.
L 44,5 W 44 H 43,1 cm

01.

02.

ECLISSE

misure / size L/W 55 P/D 44 H 45 cm

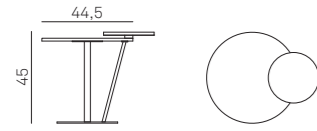

FINITURE BASAMENTO E VASSOIO / BASE AND TRAY FINISHES

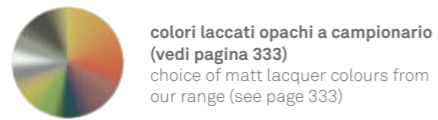

FINITURE PIANO / TOP FINISHES

MATERICO ESSENZA / TEXTURED WOOD



MT-FO
Frassino Oriente
Eastern Ash



MT-RT
Rovere termocotto
Heat-treated Oak

MATERICO NODATO / KNOTTED TEXTURED



MT-RNC
Nodato chiaro
Light Knotted

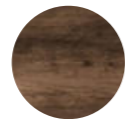

MT-RNS
Nodato scuro
Dark knotted

MATERICO OPACO / MATT MATERIC



MT-OC BG
Bianco Gesso
Chalk white



MT-OC MP
Madreperla
Mother of pearl



MT-OC AN
Antracite
Anthracite

MATERICO / TEXTURED



MT-CC
Cemento chiaro
Light cement



MT-CS
Cemento scuro
Dark cement

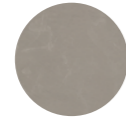

MT-CV
Cemento cava
Cava cement

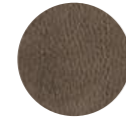

MT-MB
Maya Bronze



MT-INT C
Intreccio chiaro

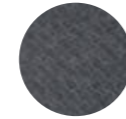

MT-INT S
Intreccio scuro

MATERICO PORO APERTO / OPEN PORE MATERIC



MT-PA BG
Bianco Gesso
Chalk white



MT-PA MP
Madreperla
Mother of pearl

LEGNO LACCATO PORO APERTO / OPEN-PORE LACQUERED WOOD



221 PA
Bianco Gesso
Chalk white



222 PA
Panna
Cream



224 PA
Madreperla
Mother of pearl



227 PA
Hot
Hot grey



230 PA
Grigio Piacenza
Piacenza grey



250 PA
Canapa
Hemp

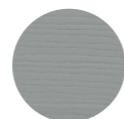

252 PA
Pomice
Pumice

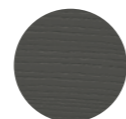

260 PA
Antracite
Anthracite

LACCATI / LACQUERS

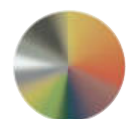

colori laccati opachi e lucidi a campionario (vedi pagina 333)
choice of matt and gloss lacquer colours from our range (see page 333)



ECLISSE

Tavolino Eclisse laccato opaco bianco gesso 121, materico nodato scuro. L 55 P 45 H 45 cm

Eclisse coffee table in matt chalk white 121 lacquer and textured dark knotted finish. L 55 W 45 H 45 cm

BRIGITTE

Tavolini Brigitte
01. Piano Hpl 11, struttura metallo hot 127.
Ø 45 H 52 cm
02. Piano Hpl 11, struttura salvia 159.
Ø 45 H 52 cm
03. Piano Hpl 11, struttura hot 127.
Ø 100 H 30 cm

Tappeto Gradient.

Brigitte coffee tables
01. HPL 11 top, hot grey 127 metal frame.
Ø 45 H 52 cm
02. HPL 11 top, sage 159 frame.
Ø 45 H 52 cm
03. HPL 11 top, hot grey 127 frame.
Ø 100 H 30 cm

Gradient rug.



01.

02.

03.

BRIGITTE



Piano materico cemento chiaro, struttura metallo bianco gesso 121. Textured light knotted top, chalk white 121 metal frame.



Piano laccato opaco antracite 160, struttura metallo bordeaux 156. Matt anthracite 160 lacquered top, burgundy 156 metal frame.

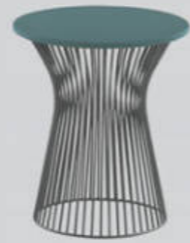

Piano laccato opaco salvia 159, struttura metallo antracite 160. Matt sage 159 lacquered top, anthracite 160 metal frame.



Piano laccato opaco smoke 128, struttura metallo smoke 128. Matt smoke 128 lacquered top, smoke 128 metal frame.



Piano materico nodato chiaro, struttura metallo antracite 160. Textured light knotted top, anthracite 160 metal frame.

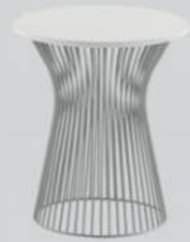

Piano laccato opaco bianco gesso 121, struttura metallo pomice 152. Chalk white 121 lacquered top, pumice 152 metal frame.



Piano materico nodato scuro, struttura metallo antracite 160. Textured dark knotted top and anthracite 160 metal frame.



Piano in Hpl 11, struttura metallo antracite 160. HPL 11 top, anthracite 160 metal frame.



Tavolino Brigitte piano Hpl 11, struttura metallo hot 127. Ø 45 H 52 cm

Brigitte coffee table with HPL 11 top, hot grey 127 metal frame. Ø 45 H 52 cm

BRIGITTE

misure / size Ø 45 H 52 cm Ø 100 H 30 cm

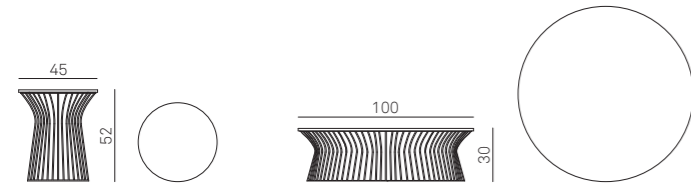

FINITURE BASAMENTO / BASE FINISHES



FINITURE PIANO / TOP FINISHES

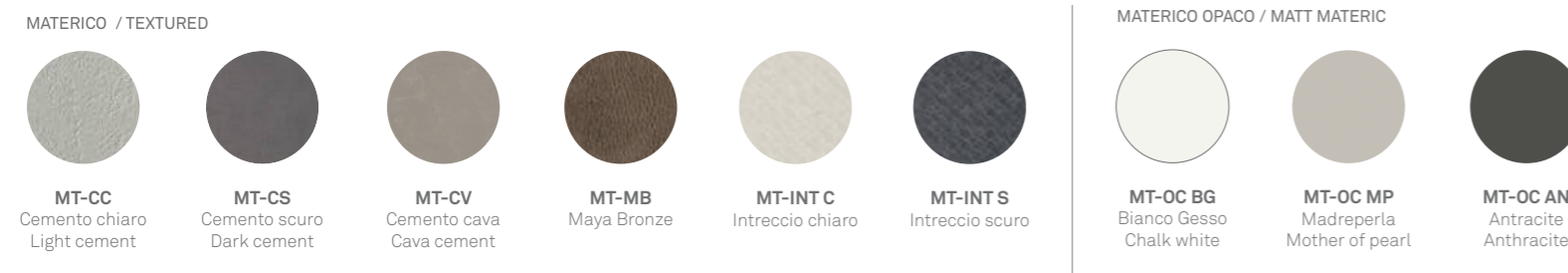
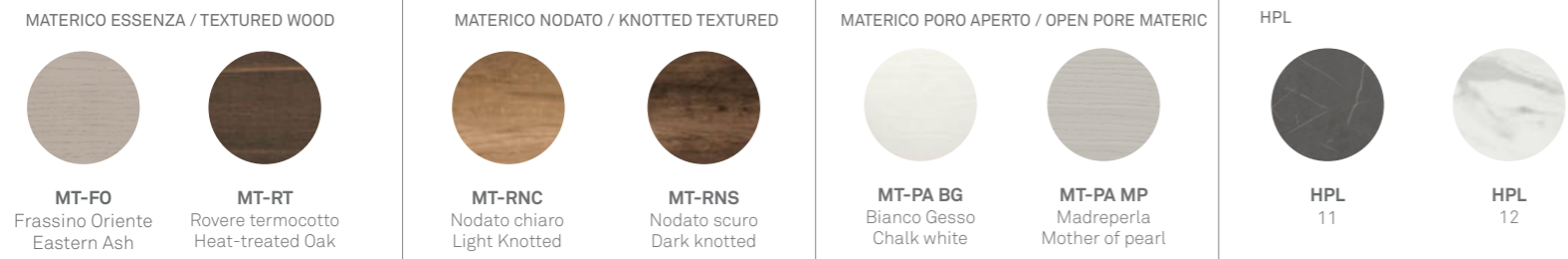

LEGNO LACCATO PORO APERTO / OPEN-PORE LACQUERED WOOD



LACCATI / LACQUERS

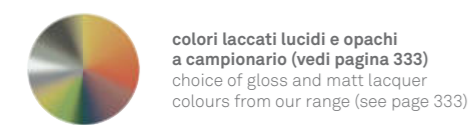

STRIKE



A destra: tavolini Strike versione Glamour e White, a sinistra: tavolini Strike versione Natural

On the right: Glamour and White Strike coffee tables, on the left: Natural Strike coffee tables.

STRIKE

misure / size L/W 80 P/D 40 H 28,4 cm L/W 80 P/D 80 H 28,4 cm
L/W 120 P/D 40 H 28,4 cm L/W 120 P/D 120 H 28,4 cm

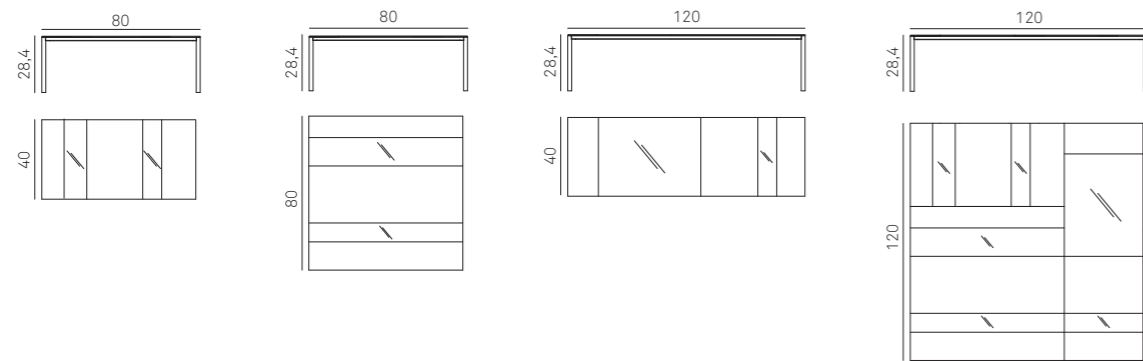

NATURAL STYLE

FINITURE PIANO / TOP FINISHES



MT-RNC
Nodato chiaro
Light knotted



VETRO/GLASS
hot 327
hot grey 327

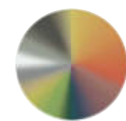

metallo opaco a campionario (pag 333)
choice matt metal colours from our range (pag 333)

FINITURE STRUTTURA / BASE FINISHES

GLAMOUR STYLE

FINITURE PIANO / TOP FINISHES



PORO APERTO
hot 227
hot grey 227



VETRO/GLASS
smoke 328
smoke 328

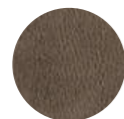

MATERICO/TEXTURED MT-MB
Maya Bronze

FINITURE STRUTTURA / BASE FINISHES

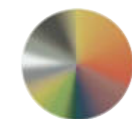

metallo opaco a campionario (pag 333)
choice matt metal colours from our range (pag 333)

WHITE STYLE

FINITURE PIANO / TOP FINISHES



PA-BG
Bianco gesso
Chalk white



VETRO/GLASS
madreperla 324
mother of pearl 324

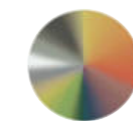

metallo opaco a campionario (pag 333)
choice matt metal colours from our range (pag 333)

FINITURE STRUTTURA / BASE FINISHES





^
BLOOM

Tavolini Bloom piano vetro trasparente 320, struttura legno rovere termocotto.
 Ø 41 H 62 cm
 Ø 56 H 47 cm
 Wallpaper WPT534.

Bloom coffee tables with transparent 320 glass top, heat-treated oak wood frame.
 Ø 41 H 62 cm
 Ø 56 H 47 cm
 WPT534 wallpaper.

BLOOM

Tavolino Bloom piano vetro trasparente 320, struttura legno rovere termocotto.
 Ø 56 H 47 cm

Bloom coffee table with transparent 320 glass top, heat-treated oak wood frame.
 Ø 56 H 47 cm





Tavolino Bloom piano vetro trasparente 320, struttura legno rovere termocotto. L 120 P 120 H 40 cm

Bloom coffee table with transparent 320 glass top, heat-treated oak wood frame. L 120 W 120 H 40 cm

BLOOM

misure / size Ø 41 H 62 cm Ø 56 H 47 L/W 110 P/D 60 H 40 L/W 120 P/D 120 H 40

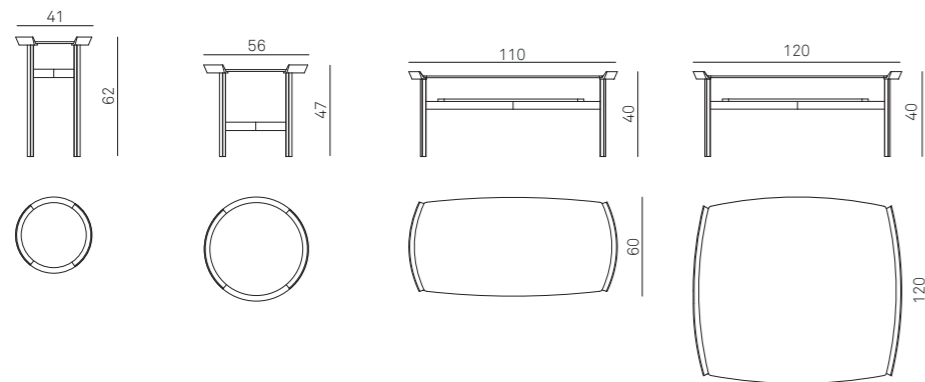

FINITURE STRUTTURA / STRUCTURE FINISHES

ESSENZE / WOOD FINISHES



LGN-FO
Frassino Oriente
Eastern Ash



LGN-RT
Rovere termocotto
Heat-treated Oak

FINITURA PIANO / TOP FINISHES



320
Vetro trasparente
Transparent glass



Tavolino Bloom piano vetro trasparente 320, struttura legno rovere termocotto. L 110 P 60 H 40 cm

Quadri Elegance Style XS.

Bloom coffee table with transparent 320 glass top, heat-treated oak wood frame. L 110 W 60 H 40 cm

Style XS Elegance Quadri.

FLEXO



Tavolino Flexo piano laccato opaco smoke 128, piano grande laccato opaco bianco gesso 121, struttura metallo bianco gesso 121.

Flexo coffee table in matt smoke 128 lacquer, large top in matt chalk white 121 lacquer, chalk white 121 metal frame.

FLEXO E SENZATEMPO

misure / size **Flexo 90:** L/W 90 P/D 75 H 27 cm
Flexo 130: L/W 130 P/D 75 H 27 cm
Flexo componibile / Modular Flexo : L/W 210 (130+90) P/D 75 H 30,5 cm
Senzatempo: L/W 120 P/D 60 H 27cm

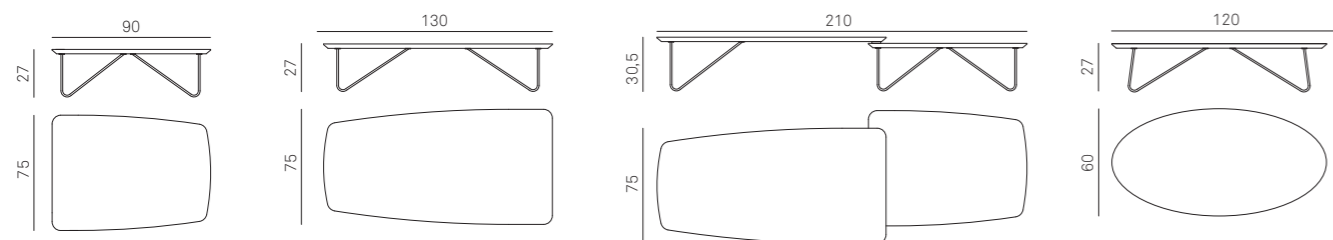

FINITURE BASAMENTO / BASE FINISHES

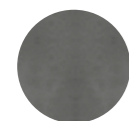

DI SERIE / STANDARD
 Finitura Peltro
 Pewter finish



DI SERIE / STANDARD
 Finitura Antracite
 Anthracite finish



colori laccati opachi a campionario
 (vedi pagina 333)
 choice of matt lacquer colours from
 our range (see page 333)

FINITURE PIANO / TOP FINISHES

LEGNO LACCATO PORO APERTO / OPEN-PORE LACQUERED WOOD



221 PA
 Bianco Gesso
 Chalk white



222 PA
 Panna
 Cream



224 PA
 Madreperla
 Mother of pearl



227 PA
 Hot
 Hot grey

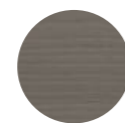

230 PA
 Grigio Piacenza
 Piacenza grey



250 PA
 Canapa
 Hemp

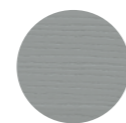

252 PA
 Pomice
 Pumice

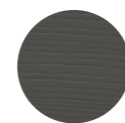

260 PA
 Antracite
 Anthracite

LACCATI / LACQUERS

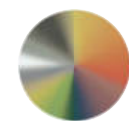

colori laccati lucidi e opachi
a campionario (vedi pagina 333)
 choice of gloss and matt lacquer
 colours from our range (see page 333)



FLEXO E SENZATEMPO

01. Tavolino Flexo laccato opaco hot
 127.
 L 90 P 75 H 27 cm

02. Tavolino Flexo piano laccato
 opaco smoke 128, piano grande
 laccato opaco bianco gesso 121,
 struttura metallo bianco gesso 121.
 L 130/90 P 75 H 30/27 cm

03. Tavolino Senzatempo
 laccato opaco smoke 128.
 L 120 P 60 H 27 cm

01. Matt hot grey 127 lacquered
 Flexo coffee table.
 L 90 W 75 H 27 cm

02. Flexo coffee table in matt
 smoke 128 lacquer, large top in
 matt chalk white 121 lacquer,
 chalk white 121 metal frame.
 L 130/90 W 75 H 30/27 cm

03. Senzatempo coffee table in
 matt smoke 128 lacquer.
 L 120 W 60 H 27 cm



Versione 10 laccato opaco bordeaux 156, pesca 157, antracite 160, madreperla 124.
Option 10 matt lacquered finish in 156 burgundy, 157 peach, 160 anthracite, 124 mother-of-pearl.

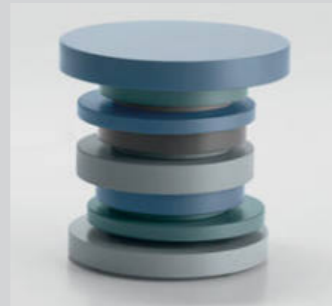

Versione 11 laccato opaco salvia 159, blu avio 154, antracite 160, carta da zucchero 155.
Option 11 matt lacquered finish in 159 sage, 154 air force blue, 160 anthracite, 155 blue grey.



Versione 12 laccato opaco antracite 160, pomice 152, bianco gesso 121.
Option 12 matt lacquered finish in 160 anthracite, 152 pumice, 121 chalk white.



Versione 13 laccato opaco zafferano 158, smoke 128, arancio 148, verde muschio 153.
Option 13 matt lacquered finish in 158 saffron, 128 smoke, 148 orange, 153 moss green.

misure / size Ø 40 H 38 cm

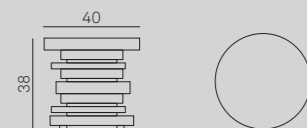

01. Tavolino 33 versione 11
02. Tavolino 33 versione 13
03. Tavolino 33 versione 12
04. Tavolino 33 versione 10
Ø 40 H 38 cm
Wallpaper WPT 515.
01. 33 coffee table, version 11.
02. 33 coffee table, version 13.
03. 33 coffee table, version 12.
04. 33 coffee table, version 10.
Ø 40 H 38 cm
WPT 515 wallpaper.

specchi

mirrors

Lineari e moderni, originali e insoliti per forma o materiale, gli specchi vanno scelti in sintonia con lo stile dell'ambiente e anche pensati per creare originali composizioni a parete.



Linear and modern, in original and unusual shapes or materials, mirrors should be chosen to suit the style of your home or arranged so as to create original wall compositions.



Uno specchio da posizionare senza una regola precisa, che porta sulla parete le forme e la magia delle bolle di sapone.

Mirrors you can position on the wall at will to conjure up some of the magical wonder of blowing bubbles.

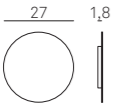
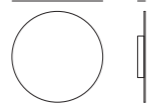
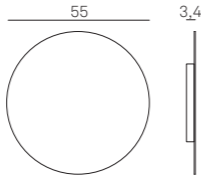
BOLLE

misure / size	ø 27 P/D 1,8	ø 35 P/D 2,9	ø 55 P/D 3,4	finitura / finish
				 Specchio Mirror



Design allo specchio.
Il pannello specchiato amplia l'ambiente,
mentre gli inserti contenitori aumentano lo spazio.

Design through the looking glass.
The mirrored panel makes the room look bigger,
while the shelving inserts add extra storage space.

misure / size L/W 54 H 108/180 (pannello Inside specchio contenitori esclusi / Inside mirrored panel not including storage units)
L/W 55 P/D 18 H 18 (elemento contenitore a giorno / open shelving unit)

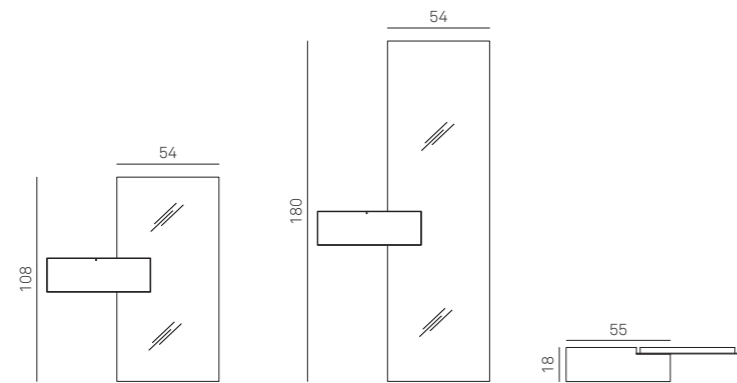

SPECCHIO / MIRROR

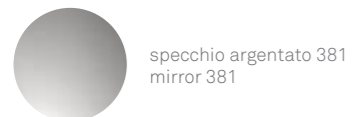

VANI A GIORNO / OPEN SHELVING

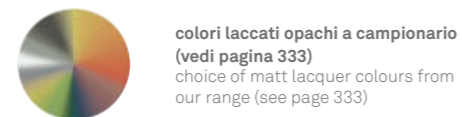

Specchiera Inside
vani a giorno metallo
madreperla 124.
L 54 P 18 H 180 cm

Kalista metallo
antracite 160.
L 27 P 36 H 80 cm

Inside mirror, mother
of pearl 124 metal open
shelving units.
W 54 D 18 H 180 cm

Anthracite 160 metal
Kalista element.
W 27 D 36 H 80 cm

HASHTAG

Specchiere Hashtag materico opaco bianco gesso, profilo laccato opaco bianco gesso 121, specchio argentato 381.

- 01. Tipo A L 65 H 125 SP - 3 cm
- 02. Tipo B L 65 H 65 SP - 3 cm
- 03. Tipo C L 100 H 72 SP - 3 cm
- 04. Tipo D L 65 H 180 SP - 3 cm

Hashtag mirrors in textured matt chalk white, matt chalk white 121 lacquered trims, silver 381 mirror.

- 01. W 65 H 125 - 3 cm thick
- 02. W 100 H 72 - 3 cm thick
- 03. W 65 H 65 - 3 cm thick
- 04. W 65 H 180 - 3 cm thick

01.



02.



03.



04.



HASHTAG

misure / size L 65 H 65 SP 3 cm L 100 H 72 SP 3 cm L 65 H 125 SP 3 cm L 65 H 180 SP 3 cm

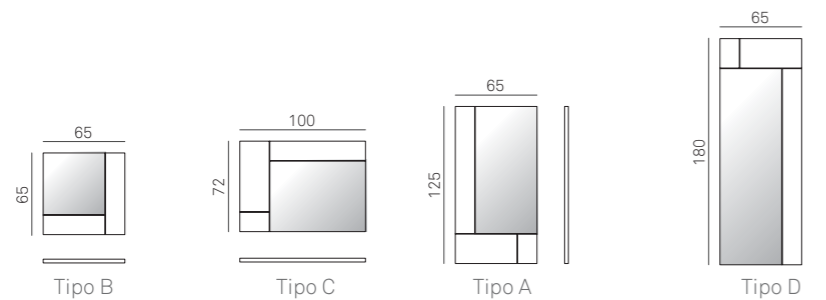

SPECCHIO / MIRROR



specchio argentato 381
mirror 381

PROFILO / PROFILE



colori laccati opachi a campionario
(vedi pagina 333)
choice of matt lacquer colours from our
range (see page 333)

CORNICE / FRAME

MATERICO NODATO / KNOTTED TEXTURED



MT-RNC
Nodato chiaro
Light Knotted



MT-RNS
Nodato scuro
Dark knotted

MATERICO OPACO / MATT TEXTURED

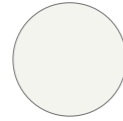

MT-OC BG
Bianco Gesso
Chalk white



MT-OC MP
Madreperla
Mother of pearl

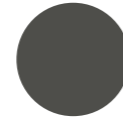

MT-OC AN
Antracite
Anthracite

MATERICO / TEXTURED



MT-CC
Cemento chiaro
Light cement



MT-CS
Cemento scuro
Dark cement

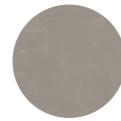

MT-CV
Cemento Cava
Cava cement

LACCATI / LACQUERS

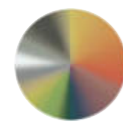

colori laccati opachi a campionario
(vedi pagina 333)
choice of matt lacquer colours
from our range (see page 333)



VIP

misure / size L 101,8 H 66,9 SP 6 cm L 69,8 H 178,9 SP 6 cm

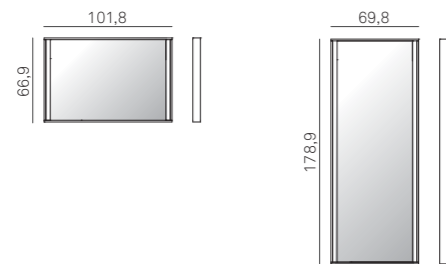

SPECCHIO / MIRROR



specchio argentato 381
silver mirror 381

CORNICE / FRAME

ESSENZE / WOOD FINISHES



LGN-FO
Frassino Oriente
Eastern Ash



LGN-RT
Rovere termocotto
Heat-treated Oak

LEGNO LACCATO PORO APERTO / OPEN-PORE LACQUERED WOOD



221 PA
Bianco Gesso
Chalk white



222 PA
Panna
Cream



224 PA
Madreperla
Mother of pearl



227 PA
Hot
Hot grey

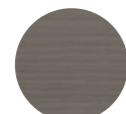

230 PA
Grigio Piacenza
Piacenza grey



250 PA
Canapa
Hemp

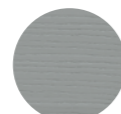

252 PA
Pomice
Pumice

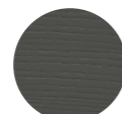

260 PA
Antracite
Anthracite

LACCATI / LACQUERS

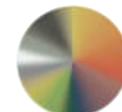

colori laccati opachi e
lucidi a campionario
(vedi pagina 333)
choice of matt and glossy
lacquer colours from our
range (see page 333)



VIP

Specchiera Vip laccato poro aperto madreperla 224.
L 101,8 H 66,9 SP - 6 cm

Vip mirror in open-pore mother of pearl 224 lacquer.
W 101.8 H 66.9 - 6 cm thick

DOLCEVITA

misure / size L 126 H 78 SP 6,5 cm

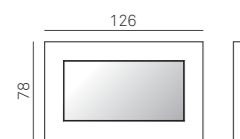

SPECCHIO / MIRROR



specchio argentato 381
mirror 381

CORNICE / FRAME

ESSENZE / WOOD FINISHES



LGN-FO
Frassino Oriente
Eastern Ash



LGN-RT
Rovere termocotto
Heat-treated Oak

LEGNO LACCATO PORO APERTO / OPEN-PORE LACQUERED WOOD



221 PA
Bianco Gesso
Chalk white



222 PA
Panna
Cream



224 PA
Madreperla
Mother of pearl



227 PA
Hot
Hot grey

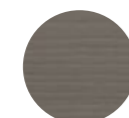

230 PA
Grigio Piacenza
Piacenza grey



250 PA
Canapa
Hemp

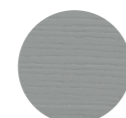

252 PA
Pomice
Pumice

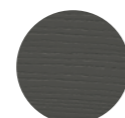

260 PA
Antracite
Anthracite

LACCATI / LACQUERS



**colori laccati opachi e
lucidi a campionario
(vedi pagina 333)**
choice of matt and glossy
lacquer colours from our
range (see page 333)



DOLCEVITA

Specchiera Dolcevita legno laccato poro aperto
bianco gesso 221.
L 126 H 78 SP - 6,5 cm

Dolcevita mirror in open pore chalk white 121
lacquered wood.
W 126 H 78 - 6.5 cm thick

accessori

accessories

Gli accessori arredano, decorano e valorizzano gli ambienti.
Tanti oggetti e complementi per gli amanti dell'home style.

Accessories furnish, decorate and enhance your interiors.
A wealth of homewares and occasional furniture for home style enthusiasts.





Kalista
 01. metallo bianco gesso 121.
 02. metallo antracite 160.
 03. metallo salvia 159.
 04. metallo zafferano 158.
 05. metallo carta da zucchero 155.
 06. metallo bordeaux 156.
 L 27 P 36 H 80 cm
 Wallpaper WPT 512.

Kalista
 01. chalk white 121 metal.
 02. anthracite 160 metal.
 03. sage 159 metal.
 04. saffron 158 metal.
 05. blue grey 155 metal.
 06. burgundy 156 metal.
 W 27 D 36 H 80 cm
 WPT 512 wallpaper.



KALISTA

Kalista metallo madreperla 124.
 L 27 P 36 H 80 cm

Mother of pearl 124 metal Kalista.
 W 27 D 36 H 80 cm



KALISTA MIDI

Kalista Midi struttura
metallo bianco gesso 121.
L 60 P 40 H 160 cm

Kalista Midi with chalk
white 121 metal frame.
W 60 D 40 H 160 cm

KALISTA

misure / size **Kalista:** L/W 27 P/D 36 H 80 cm **Kalista Midi:** L/W 60 P/D 40 H 160 cm **Kalista Fianco:** L/W 45 P/D 24 H 210 cm

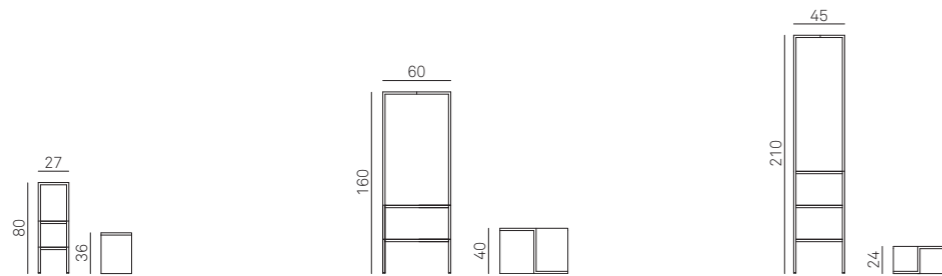

FINITURE BASAMENTO / BASE FINISHES

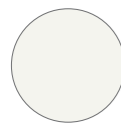

DI SERIE / STANDARD
Bianco gesso 121
White lacquered 121

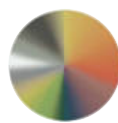

colori laccati opachi a campionario
(vedi pagina 333)
choice of matt lacquer colours from
our range (see page 333)



KALISTA FIANCO

Kalista Fianco struttura
metallo bianco gesso 121.
L 45 P 24 H 210 cm

Kalista Fianco side element
with chalk white 121 metal frame.
W 45 D 24 H 210 cm

Libreria Movida struttura metallo
bianco gesso 121, ripiani materico
nodato scuro.
L 38 P 38 H 190 cm
L 74 P 38 H 190 cm

Sedia Tiffany struttura legno laccato
poro aperto antracite 260, rivestimento
cat. b ecopelle vintage 107.
L 46 P 50 H 83/47 cm

Pouf Comodo 03.
L 85 P 85 H 85 cm

Movida bookcase with chalk white 121
metal frame and textured dark knotted
shelves.
W 38 D 38 H 190 cm
W 74 D 38 H 190 cm

Tiffany chair with wooden frame in open-
pore anthracite 260 lacquer upholstered
with cat. b vintage 107 eco-leather.
W 46 D 50 H 83/47 cm

Comodo pouf 03.
W 85 D 85 H 85 cm

MOVIDA



MOVIDA

misure / size

L/W 38 P/D 38 H 190

L/W 74 P/D 38 H 190

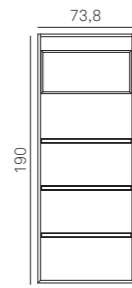
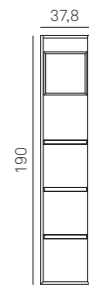

FINITURE STRUTTURA / STRUCTURE FINISHES



DI SERIE / STANDARD
Finitura Antracite
Anthracite finish

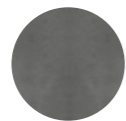

Finitura Peltro
Pewter finish



colori laccati opachi a campionario
(vedi pagina 333)
choice of matt lacquer colours from
our range (see page 333)

FINITURE PEDRO E RIPIANI / OPEN UNIT AND SHELF FINISHES

MATERICO NODATO / KNOTTED TEXTURED



MT-RNC
Nodato chiaro
Light Knotted



MT-RNS
Nodato scuro
Dark knotted

MATERICO ESSENZA / TEXTURED WOOD



MT-FO
Frassino Oriente
Eastern Ash



MT-RT
Rovere termocotto
Heat-treated Oak

MATERICO PORO APERTO / OPEN PORE TEXTURED



MT-PA BG
Bianco Gesso
Chalk white



MT-PA MP
Madreperla
Mother of pearl

MATERICO OPACO / MATT TEXTURED

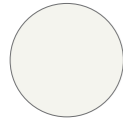

MT-OC BG
Bianco Gesso
Chalk white



MT-OC MP
Madreperla
Mother of pearl



MT-OC AN
Antracite
Anthracite

MATERICO / TEXTURED



MT-CC
Cemento chiaro
Light cement



MT-CS
Cemento scuro
Dark cement

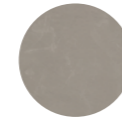

MT-CV
Cemento cava
Cava cement

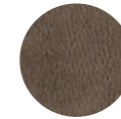

MT-MB
Maya Bronze

LEGNO LACCATO PORO APERTO / OPEN-PORE LACQUERED WOOD



221 PA
Bianco Gesso
Chalk white



222 PA
Panna
Cream



224 PA
Madreperla
Mother of pearl



227 PA
Hot
Hot grey



230 PA
Grigio Piacenza
Piacenza grey



250 PA
Canapa
Hemp

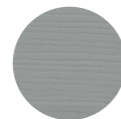

252 PA
Pomice
Pumice

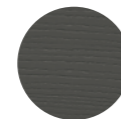

260 PA
Antracite
Anthracite

LACCATI / LACQUERS

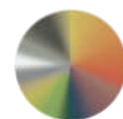

**colori laccati
lucidi e opachi
a campionario**
(vedi pagina 333)
choice of gloss and matt
lacquer colours
from our range
(see page 333)



Libreria Movida struttura metallo antracite 160, ripiani materico nodato scuro.
L 74 P 38 H 190 cm

Movida bookcase with anthracite 160 metal frame and textured dark knotted shelves.
W 74 D 38 H 190 cm

Scrivania Raster piano materico nodato scuro, struttura metallo antracite 160.
L 120 P 70 H 87 cm

Raster desk with textured dark knotted top and anthracite 160 metal frame.
L 120 W 70 H 87 cm

Pouff Guccino cat. b econabuk 05, laccato opaco madreperla 124.
Ø 40 H 53 cm

Guccino pouf in cat. b eco-nubuck 05 and matt mother of pearl 124 lacquer.
Ø 40 H 53 cm

Raster
vani a giorno orizzontali e verticali in
molteplici combinazioni di colore.
Raster orizzontale: L 144 P 30,5 H 18 cm
Raster verticale: L 18 P 30,5 H 144 cm

Raster
horizontal and vertical open shelving
units in lots of colour combinations.
Horizontal raster: W 144 D 30.5 H 18 cm
Vertical raster: W 18 D 30.5 H 144 cm

RASTER



RASTER

misure / size Raster orizzontale / horizontal: L/W 144 P/D 30,5 H 18 cm
 Raster verticale / vertical: L/W 18 P/D 30,5 H 144 cm

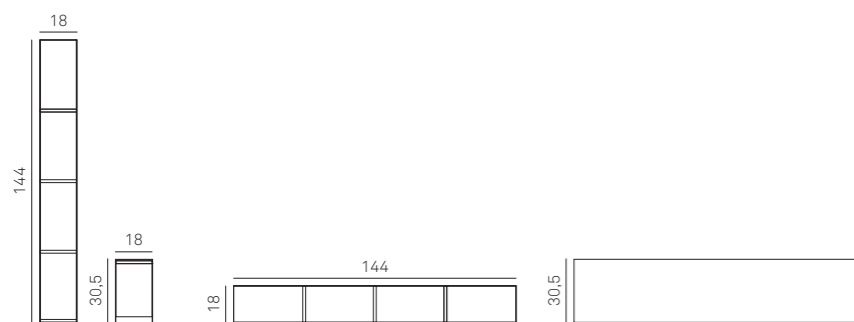

FINITURE STRUTTURA / STRUCTURE FINISHES

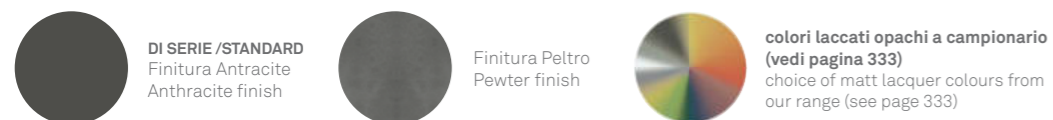

FINITURE PEDRO E RIPIANI / OPEN UNIT AND SHELF FINISHES

MATERICO NODATO / KNOTTED TEXTURED



MT-RNC
Nodato chiaro
Light Knotted



MT-RNS
Nodato scuro
Dark knotted

MATERICO ESSENZA / TEXTURED WOOD



MT-FO
Frassino Oriente
Eastern Ash



MT-RT
Rovere termocotto
Heat-treated Oak

MATERICO PORO APERTO / OPEN PORE TEXTURED



MT-PA BG
Bianco Gesso
Chalk white



MT-PA MP
Madreperla
Mother of pearl

MATERICO OPACO / MATT TEXTURED



MT-OC BG
Bianco Gesso
Chalk white



MT-OC MP
Madreperla
Mother of pearl



MT-OC AN
Antracite
Anthracite

MATERICO / TEXTURED



MT-CC
Cemento chiaro
Light cement



MT-CS
Cemento scuro
Dark cement

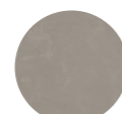

MT-CV
Cemento cava
Cava cement



MT-MB
Maya Bronze



MT-INT C
Intreccio chiaro



MT-INT S
Intreccio scuro

LEGNO LACCATO PORO APERTO / OPEN-PORE LACQUERED WOOD



221 PA
Bianco Gesso
Chalk white



222 PA
Panna
Cream



224 PA
Madreperla
Mother of pearl



227 PA
Hot
Hot grey



230 PA
Grigio Piacenza
Piacenza grey



250 PA
Canapa
Hemp



252 PA
Pomice
Pumice



260 PA
Antracite
Anthracite

LACCATI / LACQUERS

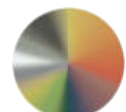

colori laccati opachi a campionario
(vedi pagina 333)
choice of matt lacquer colours
from our range (see page 333)



Raster Sospesi struttura metallo antracite 160,
inserti e schiena in materico frassino oriente.
L 144 P 30 H 18 cm

Wall-hung Raster units with anthracite 160 metal
structure and textured eastern ash
inserts and back panels.
W 144 D 30 H 18 cm

RING

misure / size L/W 108 P/D 25,6 H 27,1 cm L/W 144 P/D 25,6 H 27,1 cm
L/W162 P/D 25,6 H 27,1 cm L/W 180 P/D 25,6 H 27,1 cm

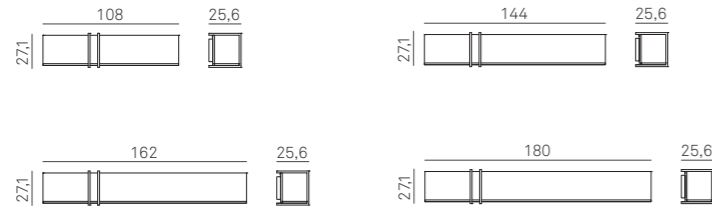

FINITURE RING / RING FINISHES

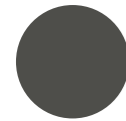

DI SERIE / STANDARD
Finitura Antracite
Anthracite finish

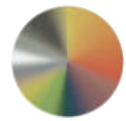

colori laccati opachi a campionario
(vedi pagina 333)
choice of matt lacquer colours from
our range (see page 333)

FINITURE STRUTTURA / STRUCTURE FINISHES

MATERICO NODATO / KNOTTED TEXTURED



MT-RNC
Nodato chiaro
Light Knotted



MT-RNS
Nodato scuro
Dark knotted

MATERICO ESSENZA / TEXTURED WOOD



MT-FO
Frassino Oriente
Eastern Ash



MT-RT
Rovere termocotto
Heat-treated Oak

MATERICO PORO APERTO / OPEN PORE TEXTURED



MT-PA BG
Bianco Gesso
Chalk white



MT-PA MP
Madreperla
Mother of pearl

MATERICO OPACO / MATT TEXTURED



MT-OC BG
Bianco Gesso
Chalk white



MT-OC MP
Madreperla
Mother of pearl



MT-OC AN
Antracite
Anthracite

MATERICO / TEXTURED



MT-CC
Cemento chiaro
Light cement



MT-CS
Cemento scuro
Dark cement



MT-CV
Cemento cava
Cava cement

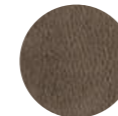

MT-MB
Maya Bronze

LEGNO LACCATO PORO APERTO / OPEN-PORE LACQUERED WOOD



221 PA
Bianco Gesso
Chalk white



222 PA
Panna
Cream



224 PA
Madreperla
Mother of pearl



227 PA
Hot
Hot grey

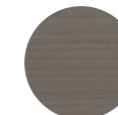

230 PA
Grigio Piacenza
Piacenza grey



250 PA
Canapa
Hemp



252 PA
Pomice
Pumice

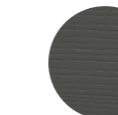

260 PA
Antracite
Anthracite

LACCATI / LACQUERS

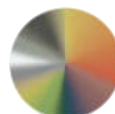

colori laccati opachi a campionario
(vedi pagina 333)
choice of matt lacquer colours from
our range (see page 333)



RING



Mensole Ring materico
nodato chiaro,
metallo bianco gesso 121.
L 144 P 25,6 H 27,1 cm

Textured light knotted and
chalk white 121 metal Ring
shelves.
L 144 D 25,6 H 27,1 cm

CIKO



Ciko varie combinazioni specchio, colori, finiture e grafiche.
L 36 P 24 H 36 cm

Various combinations of Ciko including mirrors, colours, finishes and graphic design.
W 36 D 24 H 36 cm

La schiena che decora.
Come quadri, i contenitori con schiena in laccato, specchio
o grafica animano la parete e si prestano per creare infinite
composizioni e combinazioni.

The decorative back panel.
Like pictures, these storage units liven up the wall with their
lacquered, mirrored or graphic back panels and are perfect for
mixing and matching in endless different compositions.

CIKO

misure / size L/W 36 P/D 24 H 36 cm



FINITURE STRUTTURA / CARCASS FINISHES

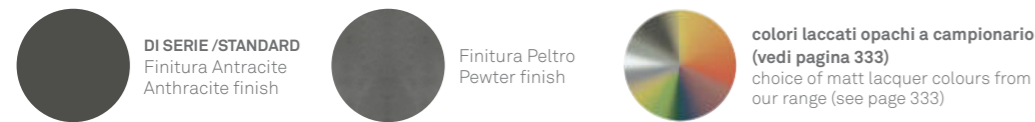

COLORI E FINITURE SCHIENA / BACK FINISHES AND COLOURS

MATERICO NODATO / KNOTTED TEXTURED



MT-RNC
Nodato chiaro
Light Knotted

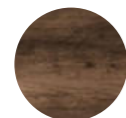

MT-RNS
Nodato scuro
Dark knotted

MATERICO ESSENZA / TEXTURED WOOD



MT-FO
Frassino Oriente
Eastern Ash



MT-RT
Rovere termocotto
Heat-treated Oak

MATERICO OPACO / MATT TEXTURED



MT-OC BG
Bianco Gesso
Chalk white



MT-OC MP
Madreperla
Mother of pearl



MT-OC AN
Antracite
Anthracite

MATERICO / TEXTURED

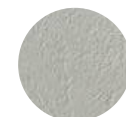

MT-CC
Cemento chiaro
Light cement



MT-CS
Cemento scuro
Dark cement



MT-CV
Cemento cava
Cava cement



MT-MB
Maya Bronze



MT-INT C
Intreccio chiaro

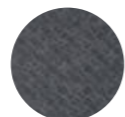

MT-INT S
Intreccio scuro

MATERICO PORO APERTO / OPEN PORE TEXTURED



MT-PA BG
Bianco Gesso
Chalk white



MT-PA MP
Madreperla
Mother of pearl

LACCATI / LACQUERS

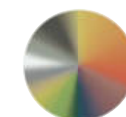

colori laccati opachi a campionario
(vedi pagina 333)
choice of matt lacquer colours from
our range (see page 333)

SPECCHIO / MIRROR



Specchio
Mirror

GRAFICHE SCHIENA / BACK PANEL GRAPHIC DESIGNS



202



203



205



206



207

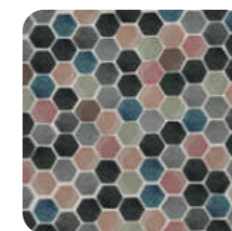

209



211



212



213

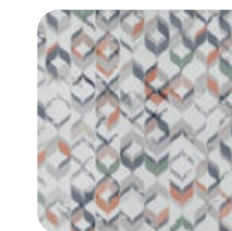

215



216



230



231



235



236



237

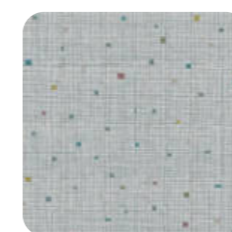

238

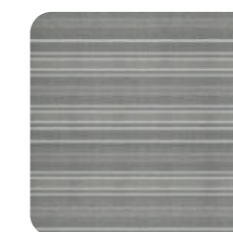

252

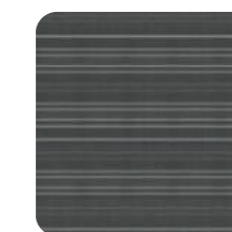

253



260



Pensili Petalo metallo bordeaux 156.
L 60/80 H 22 P 18 cm
Wallpaper WPT 536.
Burgundy 156 metal Petalo wall units.
W 60/80 H 22 D 18 cm
WPT 536 wallpaper.

PETALO

misure / size L60 P18 H 22 cm DX e SX / RH and LH L80 P18 H 22 cm DX e SX / RH and LH



FINITURE / FINISHES



colori laccati opachi a campionario
(vedi pagina 333)
choice of matt lacquer colours from our
range (see page 333)

ESEMPI COMPOSIZIONI / EXAMPLES OF ARRANGEMENTS



PETALO

Pensili Petalo metallo salvia 159. L 60/80 H 22 P 18 cm
Wallpaper WPT 550.
Sage 159 metal Petalo wall units. W 60/80 H 22 D 18 cm
WPT 550 wallpaper.



Scrivania Atlante piano materico nodato
chiaro, struttura metallo antracite 160.
L 120 P 70 H 87 cm

Pouff Guccino cat. b econabuk 05,
laccato opaco madreperla 124.
Ø 40 H 53 cm

Atlante desk with textured light knotted top,
anthracite 160 metal frame.
L 120 W 70 H 87 cm

Guccino pouf in cat. b eco-nubuck 05 and matt
mother of pearl 124 lacquer.
Ø 40 H 53 cm

SCRITTOIO



Piano materico frassino oriente, struttura metallo antracite 160.
Textured eastern ash top and anthracite 160 metal frame.



Piano materico nodato scuro, struttura metallo madreperla 124.
Textured dark knotted top and mother of pearl 124 metal frame.



Piano materico cemento chiaro, struttura metallo antracite 160.
Textured light cement top, anthracite 160 metal frame.



Piano laccato opaco salvia 159, struttura metallo antracite 160.
Matt sage 159 lacquered top, anthracite 160 metal frame.



Scrivania laccata opaco
bianco gesso 121.
L 120 P 70 H 87 cm

Sedia Tiffany struttura legno
laccato poro aperto bianco
gesso 221, rivestimento cat. b
ecopelle 34.
L 46 P 50 H 83/47 cm
Wallpaper WPT 507.

Desk in matt 121 chalk white
lacquer.
L 120 W 70 H 87 cm

Tiffany chair with wooden frame
in open-pore chalk white 221
lacquer upholstered with cat. b
vintage 34 eco-leather.
W 46 D 50 H 83/47 cm
WPT 507 wallpaper.

SCRITTOIO

misure / size L/W 120 P/D 70 H 87,7 cm

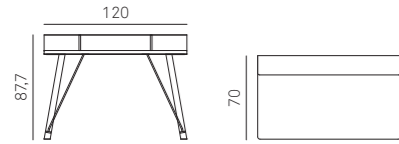

FINITURE STRUTTURA E SCHIENA / STRUCTURE AND BACK FINISHES



DI SERIE / STANDARD
Finitura Antracite
Anthracite finish



DI SERIE / STANDARD
Finitura Peltro
Pewter finish

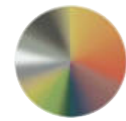

colori laccati opachi a campionario
(vedi pagina 333)
choice of matt lacquer colours from
our range (see page 333)

FINITURE PIANO E DIVISORI / TOP AND PARTITIONS FINISHES

MATERICO NODATO / KNOTTED TEXTURED



MT-RNC
Nodato chiaro
Light Knotted



MT-RNS
Nodato scuro
Dark knotted

MATERICO ESSENZA / TEXTURED WOOD



MT-FO
Frassino Oriente
Eastern Ash



MT-RT
Rovere termocotto
Heat-treated Oak

MATERICO PORO APERTO / OPEN PORE TEXTURED



MT-PA BG
Bianco Gesso
Chalk white



MT-PA MP
Madreperla
Mother of pearl

MATERICO OPACO / MATT TEXTURED

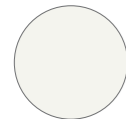

MT-OC BG
Bianco Gesso
Chalk white



MT-OC MP
Madreperla
Mother of pearl



MT-OC AN
Antracite
Anthracite

MATERICO / TEXTURED



MT-CC
Cemento chiaro
Light cement



MT-CS
Cemento scuro
Dark cement

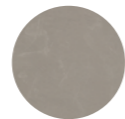

MT-CV
Cemento cava
Cava cement

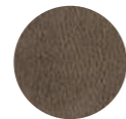

MT-MB
Maya Bronze

LEGNO LACCATO PORO APERTO / OPEN-PORE LACQUERED WOOD



221 PA
Bianco Gesso
Chalk white



222 PA
Panna
Cream



224 PA
Madreperla
Mother of pearl



227 PA
Hot
Hot grey



230 PA
Grigio Piacenza
Piacenza grey



250 PA
Canapa
Hemp

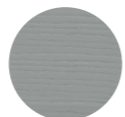

252 PA
Pomice
Pumice

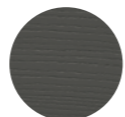

260 PA
Antracite
Anthracite

LACCATI / LACQUERS

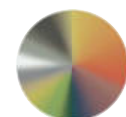

colori laccati opachi a campionario
(vedi pagina 333)
choice of matt lacquer colours from
our range (see page 333)



Scrivitoio piano materico nodato chiaro,
struttura metallo bianco gesso 121.
L 120 P 70 H 87 cm

Raster Orizzontale struttura metallo
bianco gesso 121, materico nodato chiaro.
L 144 P 30 H 18 cm

Wallpaper WPT 527.

Desk with textured light knotted top,
chalk white 121 metal frame.
L 120 W 70 H 87 cm

Horizontal Raster unit in chalk white 121
metal and textured light knotted finish.
W 144 D 30 H 18 cm

WPT 527 wallpaper.

PANKETTA



Panketta
01. materico nodato scuro e
struttura metallo bianco gesso 121.
L 216 P 38 H 45 cm

02. laccato opaco bianco gesso 121.
L 216 P 38 H 45 cm

03. materico nodato chiaro e
struttura metallo antracite 160.
L 144 P 38 H 45 cm

Panketta
01. textured dark knotted top,
chalk white 121 metal frame.
L 216 W 38 H 45 cm

02. matt chalk white 121 lacquer.
L 216 W 38 H 45 cm

03. textured light knotted and
anthracite 160 metal frame.
L 144 W 38 H 45 cm

01.

02.

03.

PANKETTA

misure / size L/W 144 P/D 38 H 45 cm L/W 180 P/D 38 H 45 cm L/W 216 P/D 38 H 45 cm

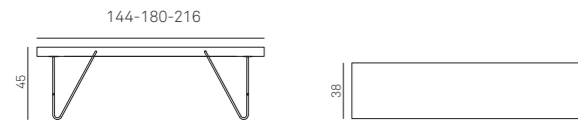

FINITURE STRUTTURA E SCHIENA / STRUCTURE AND BACK FINISHES



DI SERIE / STANDARD
Finitura Antracite
Anthracite finish

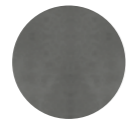

DI SERIE / STANDARD
Finitura Peltro
Pewter finish

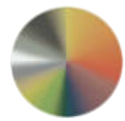

colori laccati opachi a campionario
(vedi pagina 333)
choice of matt lacquer colours from
our range (see page 333)

FINITURE PIANO E DIVISORI / TOP AND PARTITIONS FINISHES

MATERICO NODATO / KNOTTED TEXTURED



MT-RNC
Nodato chiaro
Light Knotted



MT-RNS
Nodato scuro
Dark knotted

MATERICO ESSENZA / TEXTURED WOOD



MT-FO
Frassino Oriente
Eastern Ash



MT-RT
Rovere termocotto
Heat-treated Oak

MATERICO PORO APERTO / OPEN PORE TEXTURED



MT-PA BG
Bianco Gesso
Chalk white



MT-PA MP
Madreperla
Mother of pearl

MATERICO OPACO / MATT TEXTURED

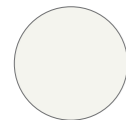

MT-OC BG
Bianco Gesso
Chalk white



MT-OC MP
Madreperla
Mother of pearl



MT-OC AN
Antracite
Anthracite

MATERICO / TEXTURED



MT-CC
Cemento chiaro
Light cement



MT-CS
Cemento scuro
Dark cement

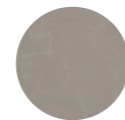

MT-CV
Cemento cava
Cava cement

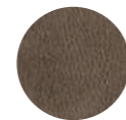

MT-MB
Maya Bronze

LEGNO LACCATO PORO APERTO / OPEN-PORE LACQUERED WOOD



221 PA
Bianco Gesso
Chalk white



222 PA
Panna
Cream



224 PA
Madreperla
Mother of pearl



227 PA
Hot
Hot grey



230 PA
Grigio Piacenza
Piacenza grey



250 PA
Canapa
Hemp

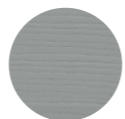

252 PA
Pomice
Pumice



260 PA
Antracite
Anthracite

LACCATI / LACQUERS

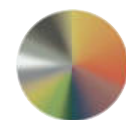

colori laccati opachi a campionario
(vedi pagina 333)
choice of matt lacquer
colours from our range (see page 333)



Panketta materico nodato
chiaro struttura metallo
antracite 160.
L 144 P 38 H 45 cm

Textured light knotted
Panketta bench with
anthracite 160 metal frame.
L 144 W 38 H 45 cm



Tasca
Sinistra: tessuto cat. b texas col. 25 e tasche in tessuto cat. b texas col. 12.
Destra: tessuto cat. b texas col. 10 e tasche in tessuto cat. b texas col. 31.
L 80 H 720 cm

Tasca
Left: cat. B texas col. 25 fabric with pockets in cat. b texas col. 12 fabric
Right: cat. B texas col. 10 fabric with pockets in cat. b texas col. 31 fabric
W 80 H 720 cm

TASCA

misure / size

Tasca: L/W 80 H 72 cm

Tasca Fianco: L/W 60 H 230 cm

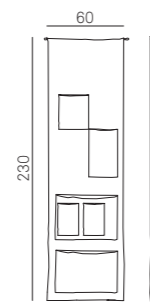
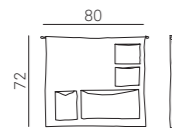

RIVESTIMENTO / COVERING

Econabuk, ecopelle e pelle
Eco-nubuck, eco-leather and leather upholstery



Tessuti del campionario
Our range of fabrics



Tasca Fianco fondo in ecopelle vintage 102, tasche in ecopelle vintage 107.
L 60 H 230 cm

Tasca Fianco for side panel: back in vintage 102 eco-leather, pockets in vintage 107 eco-leather.
W 60 H 230 cm

TASCA



TOILETTE REPLAY

misure / size L/W 120 P/D 44 H 77 cm

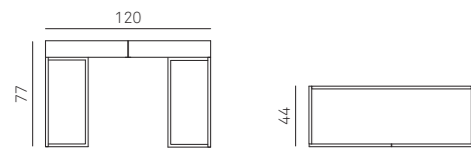

FINITURE STRUTTURA / STRUCTURE FINISHES



DI SERIE / STANDARD
Finitura Antracite
Anthracite finish

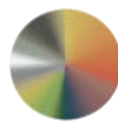

colori laccati opachi a campionario
(vedi pagina 333)
choice of matt lacquer colours
from our range (see page 333)

FINITURE TOP / TOP FINISHES



vetro lucido colorato a campionario
(vedi pagina 334)
choice of gloss coloured glass from our
range (see page 334)

FINITURE TOP E CASSETTI / TOP AND DRAWERS FINISHES

MATERICO ESSENZA / TEXTURED WOOD



MT-FO
Frassino Oriente
Eastern Ash



MT-RT
Rovere termocotto
Heat-treated Oak

MATERICO PORO APERTO / OPEN PORE TEXTURED



MT-PA BG
Bianco Gesso
Chalk white



MT-PA MP
Madreperla
Mother of pearl

MATERICO OPACO / MATT TEXTURED



MT-OC BG
Bianco Gesso
Chalk white



MT-OC MP
Madreperla
Mother of pearl



MT-OC AN
Antracite
Anthracite

MATERICO / TEXTURED



MT-CC
Cemento chiaro
Light cement



MT-CS
Cemento scuro
Dark cement

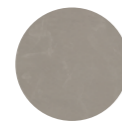

MT-CV
Cemento cava
Cava cement

LACCATI / LACQUERS

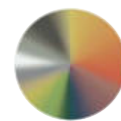

colori laccati opachi a campionario
(vedi pagina 333)
choice of matt lacquer colours
from our range (see page 333)

LEGNO LACCATO PORO APERTO / OPEN-PORE LACQUERED WOOD



221 PA
Bianco Gesso
Chalk white



222 PA
Panna
Cream



224 PA
Madreperla
Mother of pearl



227 PA
Hot
Hot grey



230 PA
Grigio Piacenza
Piacenza grey



250 PA
Canapa
Hemp

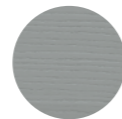

252 PA
Pomice
Pumice

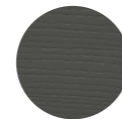

260 PA
Antracite
Anthracite

TOILETTE



Toilette Replay piano materico rovere termocotto, struttura metallo antracite 160. L 120 P 44 H 77 cm

Pouf Cookie cat. c casale 100. L 46 P 47 H 47 cm

Wallpaper WPT 552.

Replay dressing table with textured heat-treated oak top and anthracite 160 metal frame. L 120 W 44 H 77 cm

Cookie pouf cat. c casale 100. W 46 D 47 H 47 cm

WPT 552 wallpaper.

La nuova frontiera delle mensole assume forme e combinazioni inedite per dare vita e personalità alle pareti.

Pushing the boundaries of shelving with never-before-seen shapes and combinations for lively walls full of personality.

SHAPE

Composizione Shape 5B laccato opaco bianco gesso 121.

Tavolo Brigitte laccato opaco bianco gesso 121.
Ø 120 H 75 cm.

Sedia Betty cat. b ecopelle extrema 01.
L 45 P 54 H 81/46 cm.

Shape 5B arrangement in matt chalk white 121 lacquer.

Brigitte table in matt chalk white 121 lacquer.
Ø 120 H 75 cm

Betty chair upholstered with cat. b extrema 01 eco-leather.
W 45 D 54 H 81/46 cm.



SHAPE



SHAPE

Shape composizione 1B
materico nodato chiaro,
laccato opaco madreperla 124,
laccato opaco pesca 157.

Wallpaper WPT511.

Shape arrangement 1B in textured
light knotted, matt mother of pearl
124 lacquer and matt peach 157
lacquer.

WPT511 wallpaper.



SHAPE

Composizione Shape 5A, finitura
peltro e materico opaco antracite.

Shape 05A arrangement in pewter
finish and textured anthracite.



SHAPE

misure / size

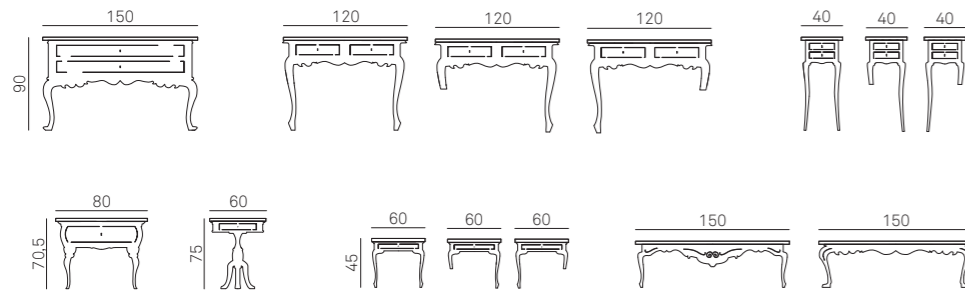

esempi composizioni / examples of arrangements

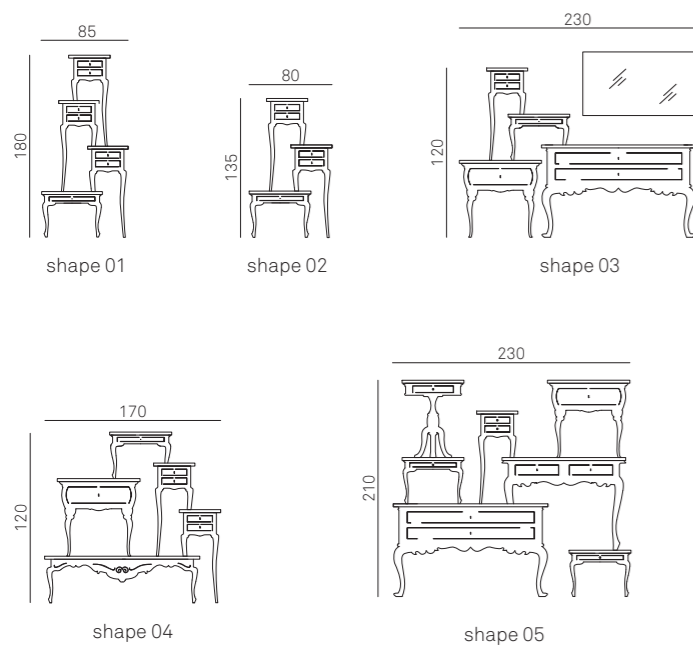

FINITURE STRUTTURA / STRUCTURE FINISHES

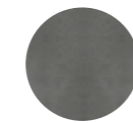

DI SERIE / STANDARD
Finitura Peltro
Pewter finish



DI SERIE / STANDARD
Finitura Antracite
Anthracite finish

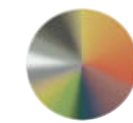

colori laccati opachi a campionario
(vedi pagina 333)
choice of matt lacquer colours from
our range (see page 333)

FINITURE MENSOLA / SHELF FINISHES

MATERICO ESSENZA / TEXTURED WOOD



MT-FO
Frassino Oriente
Eastern Ash

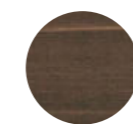

MT-RT
Rovere termocotto
Heat-treated Oak

MATERICO NODATO / KNOTTED TEXTURED



MT-RNC
Nodato chiaro
Light Knotted

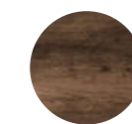

MT-RNS
Nodato scuro
Dark knotted

MATERICO PORO APERTO / OPEN PORE TEXTURED



MT-PA BG
Bianco Gesso
Chalk white



MT-PA MP
Madreperla
Mother of pearl

MATERICO / TEXTURED

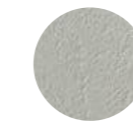

MT-CC
Cemento chiaro
Light cement



MT-CS
Cemento scuro
Dark cement

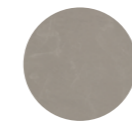

MT-CV
Cemento cava
Cava cement



MT-MB
Maya Bronze

MATERICO OPACO / MATT TEXTURED



MT-OC BG
Bianco Gesso
Chalk white



MT-OC MP
Madreperla
Mother of pearl



MT-OC AN
Antracite
Anthracite

LEGNO LACCATO PORO APERTO / OPEN-PORE LACQUERED WOOD



221 PA
Bianco Gesso
Chalk white



222 PA
Panna
Cream



224 PA
Madreperla
Mother of pearl



227 PA
Hot
Hot grey

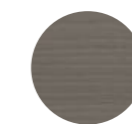

230 PA
Grigio Piacenza
Piacenza grey



250 PA
Canapa
Hemp

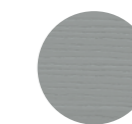

252 PA
Pomice
Pumice

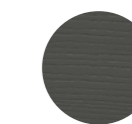

260 PA
Antracite
Anthracite

LACCATI / LACQUERS



colori laccati opachi a campionario
(vedi pagina 333)
choice of matt lacquer colours
from our range (see page 333)

INGRESSI

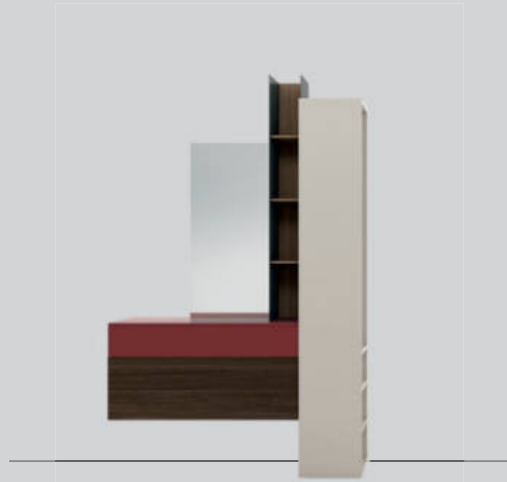

Ingresso I02 materico rovere termocotto, laccato opaco bordeaux 156, laccato opaco madreperla 124, metallo antracite 160, specchio inside.
I02 hall arrangement in textured heat-treated oak, matt burgundy 156 lacquer and matt mother of pearl 124 lacquer, anthracite 160 metal, inside mirror.

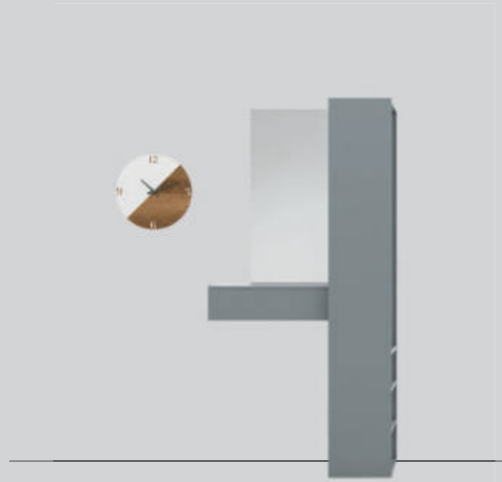

Ingresso I03 laccato opaco carta da zucchero 155, orologio 643, specchio inside.
I03 hall arrangement in matt blue grey 155 lacquer, 643 clock, inside mirror.



Ingresso I04 materico cemento chiaro, laccato opaco bianco gesso 121, metallo antracite 160, Lettering, appendiabiti Me&You peltro, specchio inside.
I04 hall arrangement in textured light cement, matt chalk white 121 lacquer, anthracite 160 metal, Lettering, pewter Me&You pegs, inside mirror.



Ingresso I05 materico frassino oriente, materico cemento chiaro, metallo salvia 159, specchio inside.
I05 hall arrangement in textured frassino oriente, textured light cement, sage 159 lacquered metal, inside mirror.

INGRESSI



Ingresso I01 laccato opaco madreperla 124, materico frassino oriente.
Raster metallo antracite 160, inserti materico frassino oriente.
L 180 P 30-40 H 234 cm
Pouff Cookie cat. c linara 02, filo rosso 0856.
Specchio Bolle. Ø 27-35-55.
Orologio 630.

I01 hall arrangement in matt mother of pearl 124 lacquer and textured eastern ash. Anthracite 160 metal Raster unit, textured eastern ash inserts.
W 180 D 30-40 H 234 cm
Cookie pouf cat. c linara 02, red 0856 yarn.
Bolle mirror Ø 27-35-55.
630 clock.



UP&DOWN

Un'altalena per volare sempre più in alto nel design. Può essere utile, come comodino o piano d'appoggio, ma anche semplicemente bella da vedere.

A swing takes design to new heights. It can be useful - as a bedside table or handy shelf - or just be beautiful to look at.

misure / size

L/W 60 P/D 30 cm

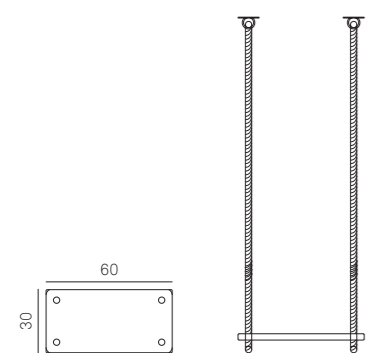

FINITURE / FINISHES

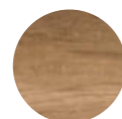

Rovere Nodato naturale
Natural knotted oak



Rovere Bianco spazzolato
Brushed white oak

UP&DOWN



Up&Down rovere nodato naturale.

Pouf Giglio cat. 1/one point 06,
cat.b ecopelle vintage 103.
L 85 P 85 H 30 cm

Up&Down natural knotted oak

Giglio floor cushion in cat. 1/one point
06 and cat. b vintage 103 eco-leather.
W 85 D 85 H 30 cm

Un elemento irrinunciabile per chi non vuole perdere tempo.
 Gli orologi da parete interpretano un classico dell'arredo
 con estrema originalità.

A must-have for all those who always finds time for good design.
 These clocks are an extremely original take on a classic piece.



misure / size

Ø 45

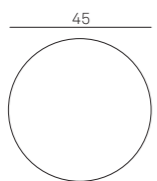

sp. 2,1 cm base metallo / 2.1 cm thick metal finish
 sp. 3,3 cm base rovere nodato chiaro / 3.3 cm thick light knotted oak finish

CLOCK

Clock collection 9 grafiche
 diverse per personalizzare
 l'orologio da parete.
 ø 45 - spessore 3,3 cm

Clock collection: 9 different
 graphic designs to customise
 your wall clock.
 ø 45 - 3.3 cm thick





Lettering Music metallo bianco gesso 121.
Chalk white 121 metal Music Lettering.

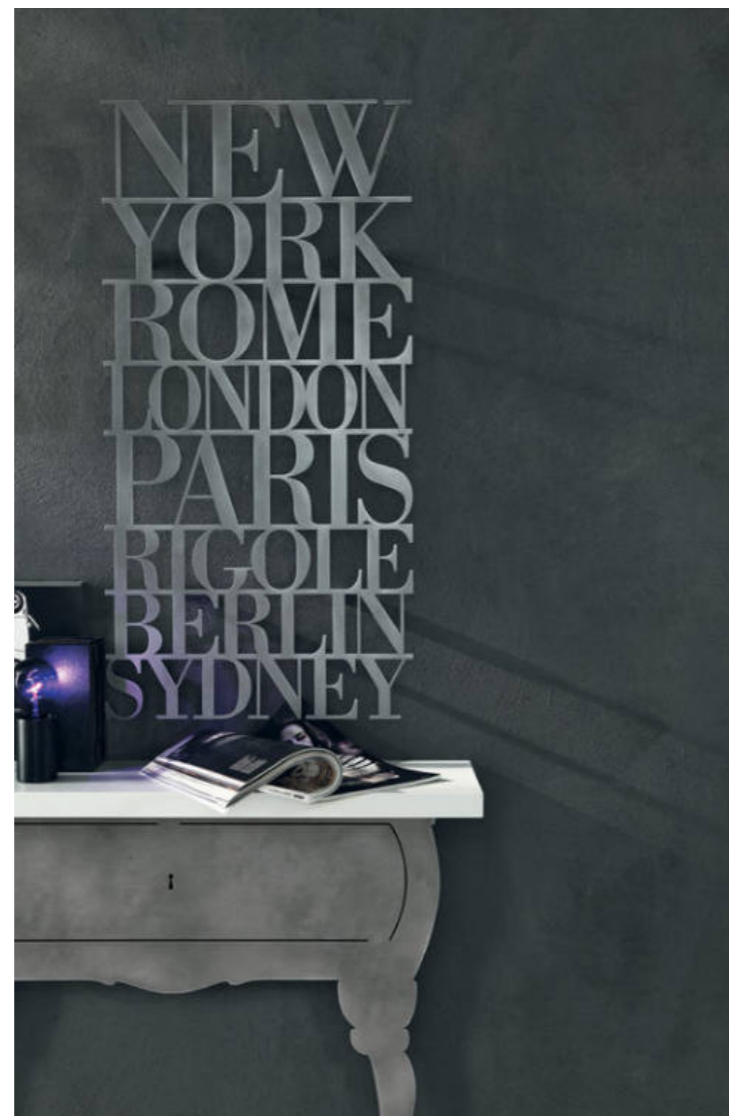

Lettering City peltro.
Pewter finish City Lettering.

LETTERING

misure / size

me&you : L 100 H 19,2 cm

music: L 42 H 60 cm

city: L 42 H 80 cm

appendiabiti/coat pegs



FINITURE STRUTTURA / FRAME FINISHES

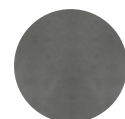

Peltro
Pewter



Antracite 160
Anthracite 160



Bianco Gesso 121
Chalk white 121



LETTERING

Lettering Me&You metallo antracite 160.
Me&You Lettering in anthracite 160 metal.

Elegance Style XS



ingombro totale / total L. 71 cm

ingombro totale / total H. 75 cm

Elegance Style S



ingombro totale / total L. 87 cm

ingombro totale / total H. 87 cm

Elegance Style M



ingombro totale / total L. 120 cm

ingombro totale / total H. 127 cm



Elegance Style L
ingombro totale L. 201 H. 184 cm

Natural Style XS



Natural Style S

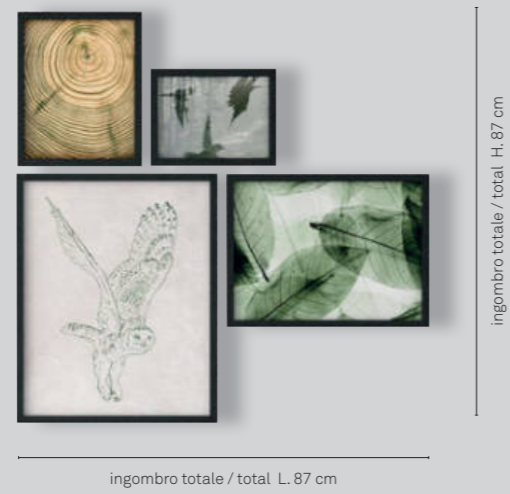

Natural Style M



Colours Style XS



Colours Style S

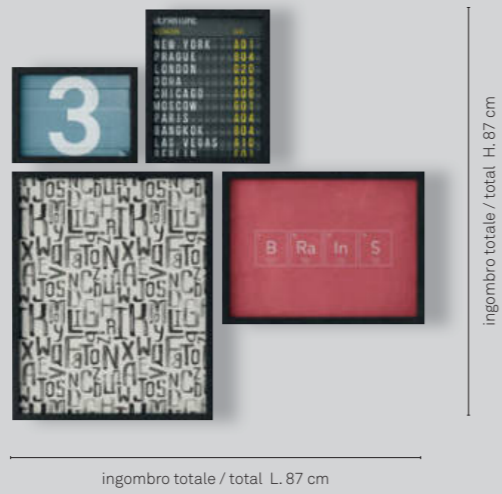

Colours Style M



Contemporary Style XS



Contemporary Style S



Contemporary Style M



Loft Style S



ingombro totale / total H. 87 cm

ingombro totale / total L. 50 cm

Loft Style M



ingombro totale / total H. 87 cm

ingombro totale / total L. 107 cm

Loft Style L



ingombro totale / total H. 134 cm

ingombro totale / total L. 107 cm



Loft Style L
ingombro totale L. 107 H. 134 cm

TAPPETI

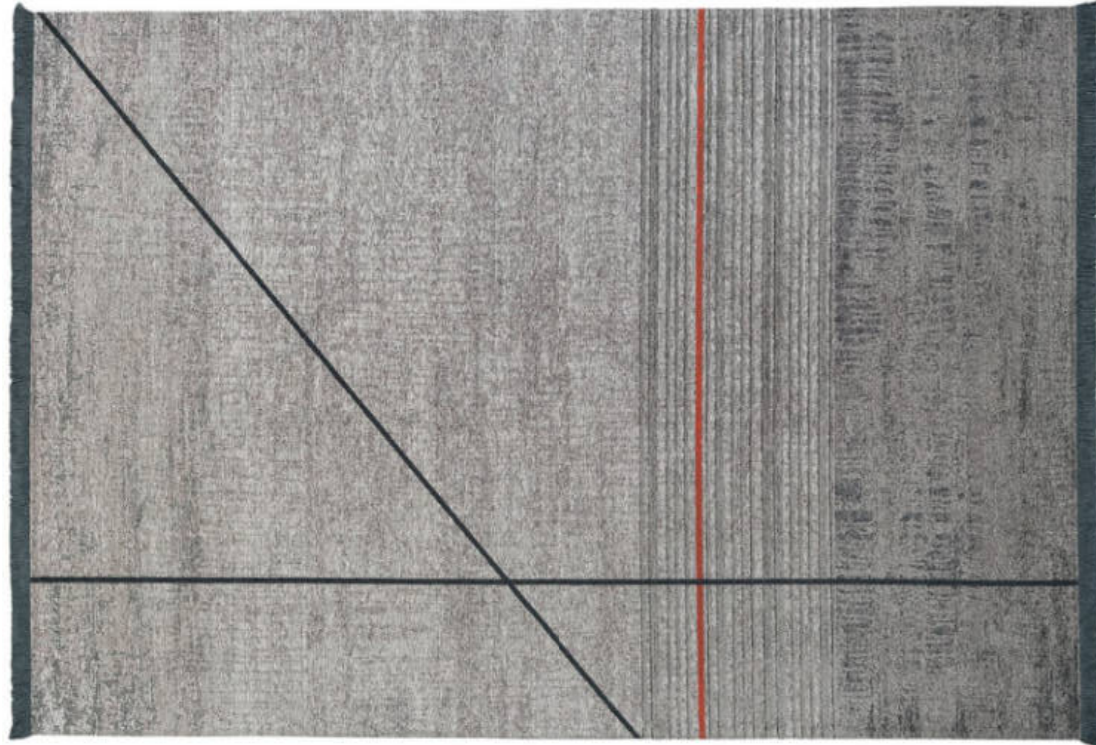

Tappeto/rug Diagonal.
L 200 P 300 cm

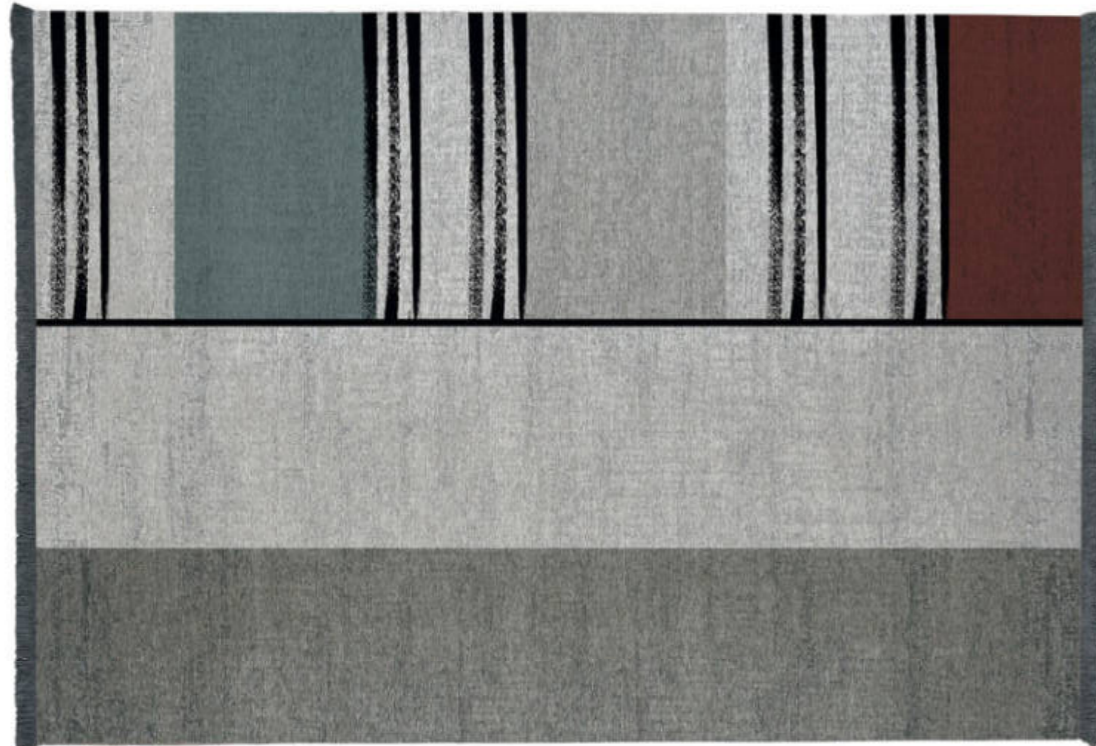

Tappeto/rug Stripes.
L 200 P 300 cm



Tappeto Diagonal.
L 200 P 300 cm

TAPPETI

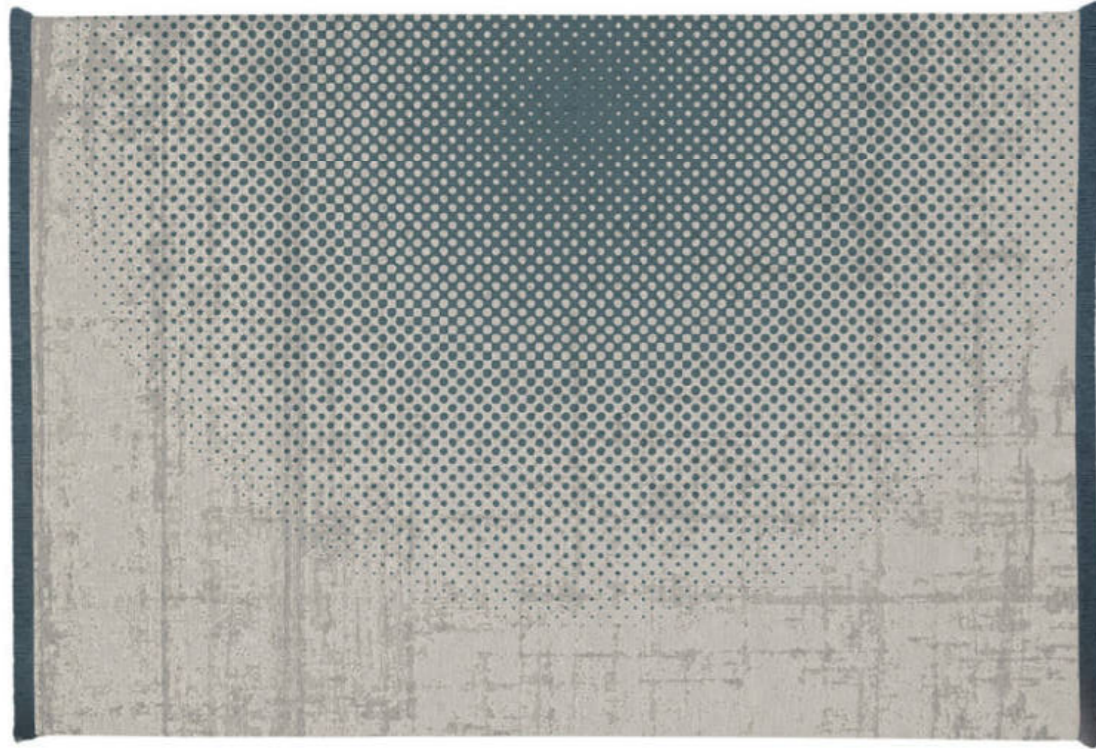

Tappeto/rug Dots.
L 200 P 300 cm

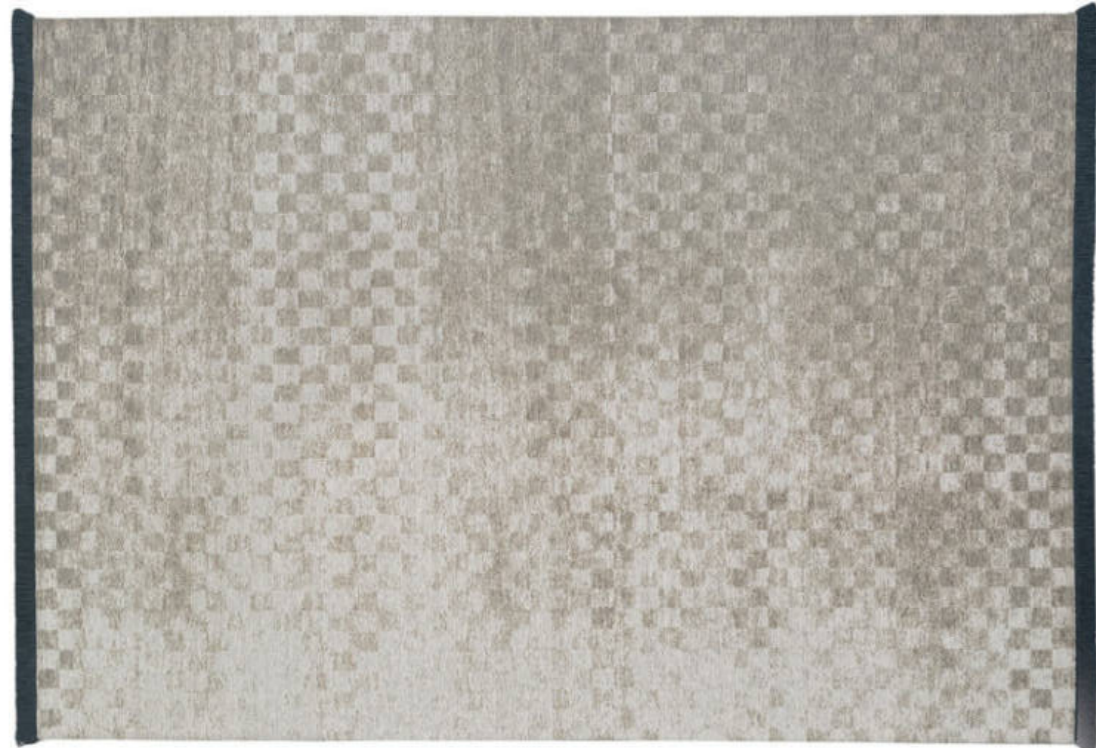

Tappeto/rug Gradient.
L 200 P 300 cm



TAPPETI

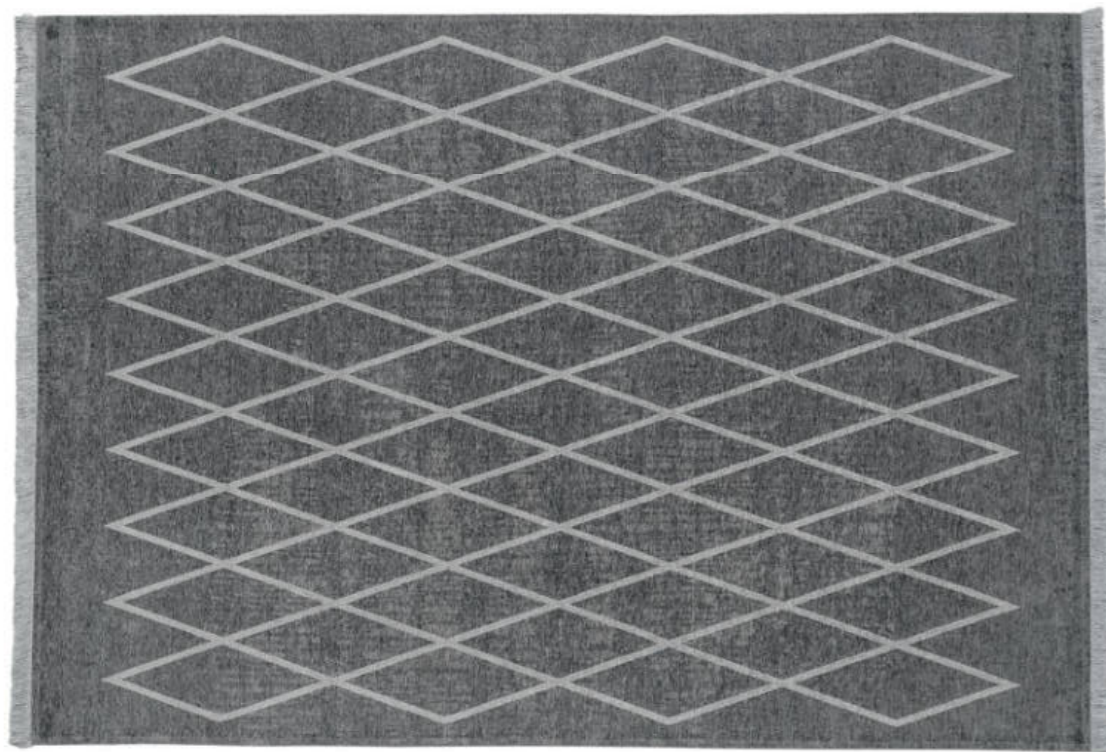

Tappeto/rug Frame.
L 200 P 300 cm



Tappeto/rug Black & White.
L 200 P 300 cm



Tappeto Stripes.
L 200 P 300 cm



Dopo la camera da letto, le coperte conquistano anche il living. Leggeri e delicati, tinta unita o colorati, i plaid scaldano e decorano sia la notte, sia il giorno.

Throws are venturing out of the bedroom and into the living room. Light and delicate, plain or colourful, throws bring warmth and a decorative touch to your days and nights.

01. Plaid Lino Sacco
misure 150x195 cm.

02. Plaid Militare
misure 150x195 cm.

03. Plaid Cuzco
misure 150x195 cm.

01. Plaid Lino Sacco
misure 150x195 cm.

02. Plaid Militare
misure 150x195 cm.

03. Plaid Cuzco
misure 150x195 cm.



01.

02.

03.

Non solo un complemento d'arredo ma il fulcro della decorazione della zona giorno e notte. gioca con diversi tessuti, forme e confezioni per creare il giusto mood per un ambiente di tendenza.

Cushions can be more than accessories: they can determine the decorative style of the day and night areas. mix and match various fabrics, shapes and styles to create the right mood for a trendy setting.

Formati / Sizes



Tipi di confezione / Styles



Colori Fili Cuciture / Colours, yarns, seams



CUSCINI



Collezione Wallpaper, tanti soggetti per decorare con creatività le pareti.

Wallpaper collection, plenty of designs for decorating walls creatively.

WALLPAPER COLLECTION

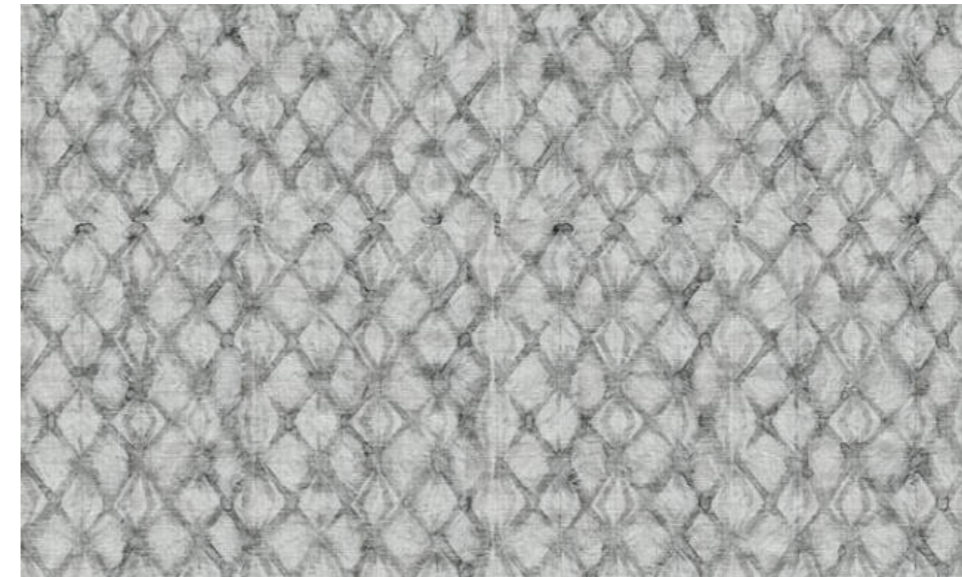

Codice/Code **WPT551**



Codice/Code **WPT550**

PAGE 126 - 179 - 271

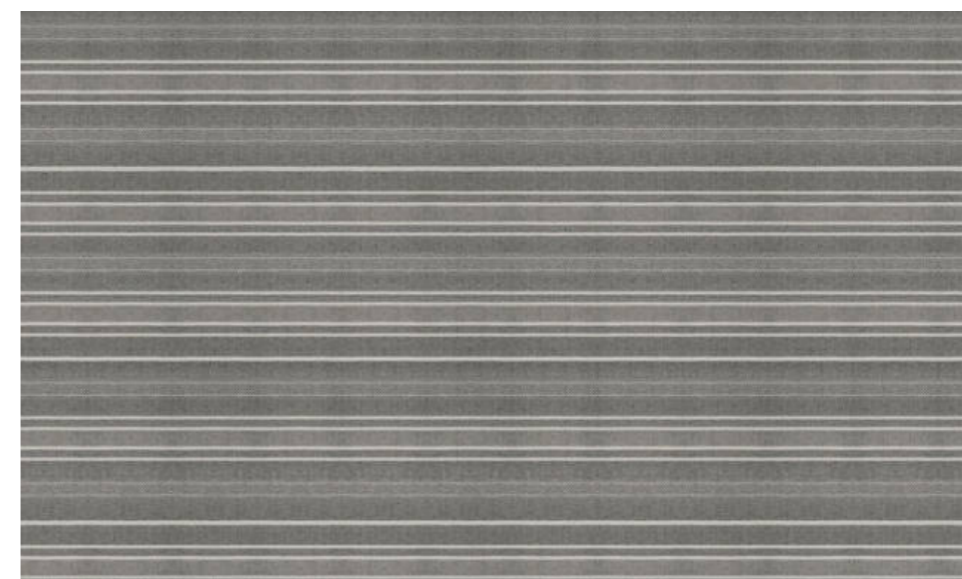

Codice/Code **WPT552**

PAGE 59 - 285

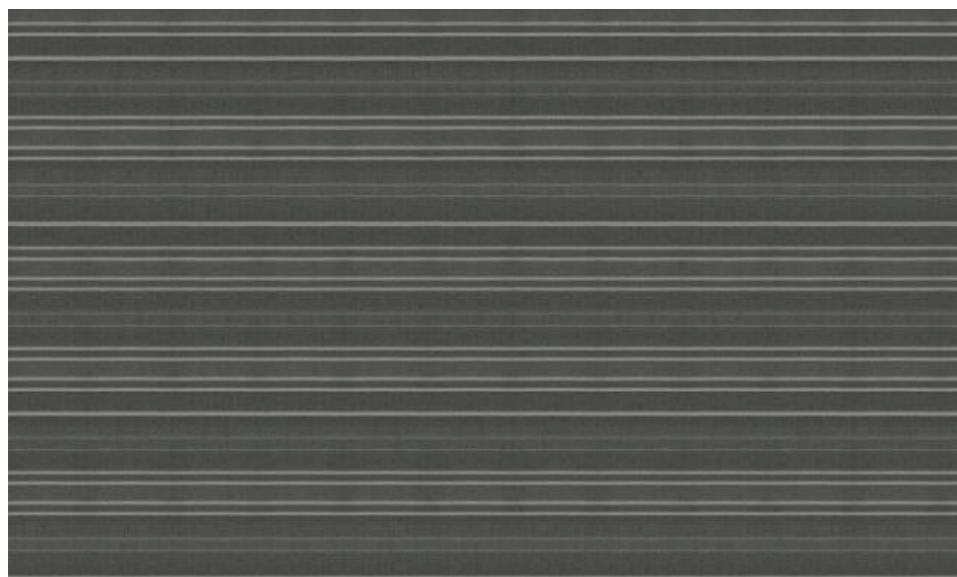

Codice/Code **WPT553**

PAGE 18 - 28 - 31 - 151

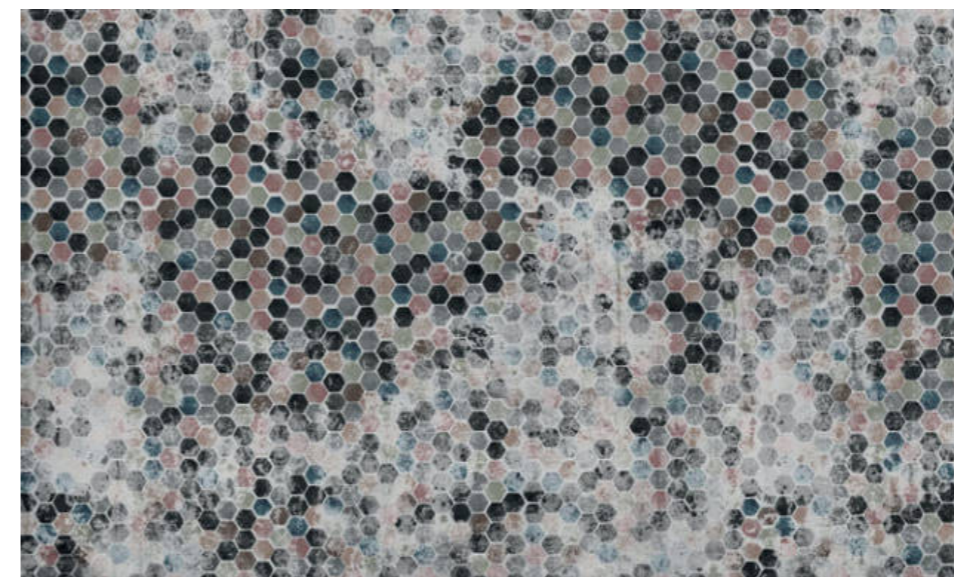

Codice/Code **WPT509**



Codice/Code **WPT560**

PAGE 61 - 251

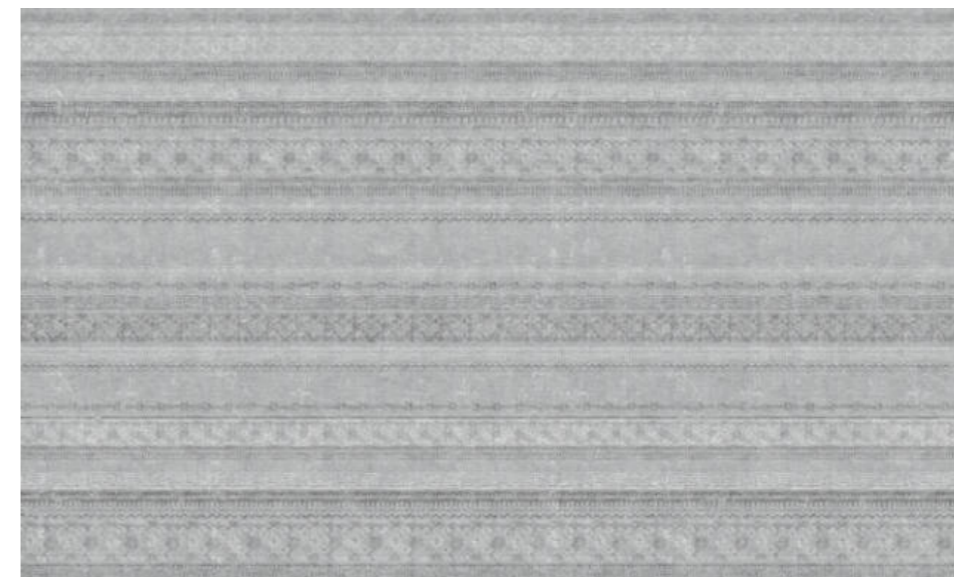

Codice/Code **WPT511**

PAGE 83 - 288

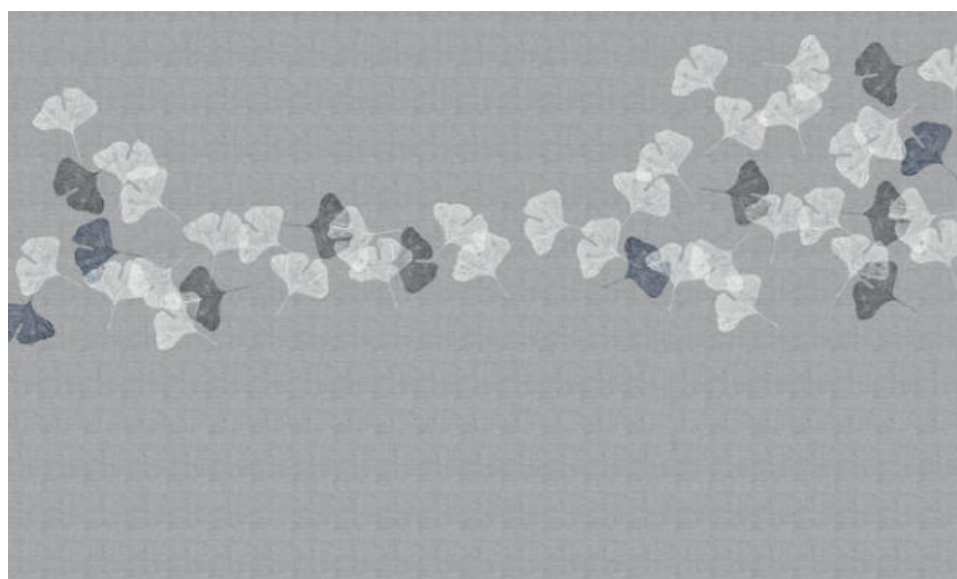

Codice/Code **WPT507**

PAGE 275



Codice/Code **WPT512**

PAGE 81 - 131 - 252

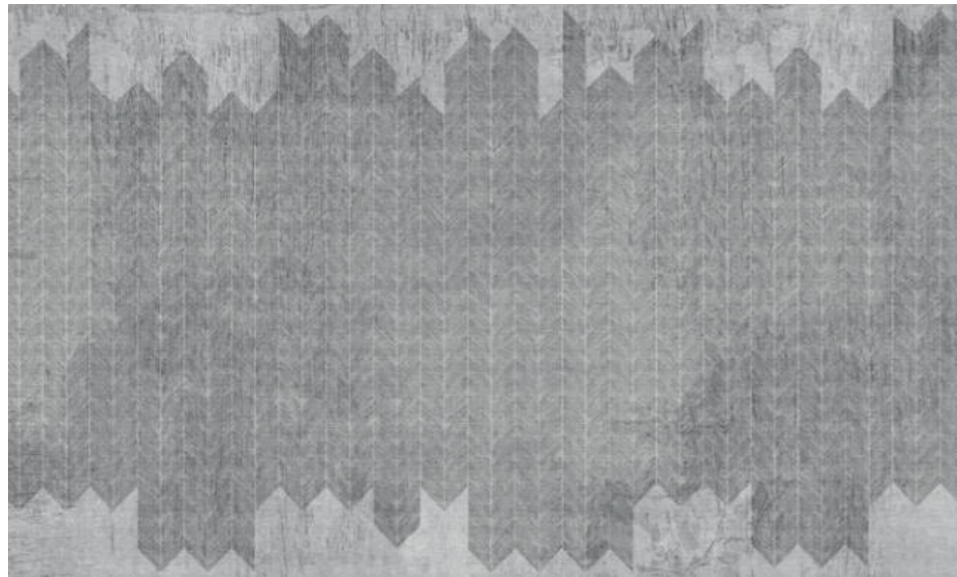

Codice/Code **WPT513**

PAGE 121 - 301 - 315



Codice/Code **WPT515**

PAGE 235

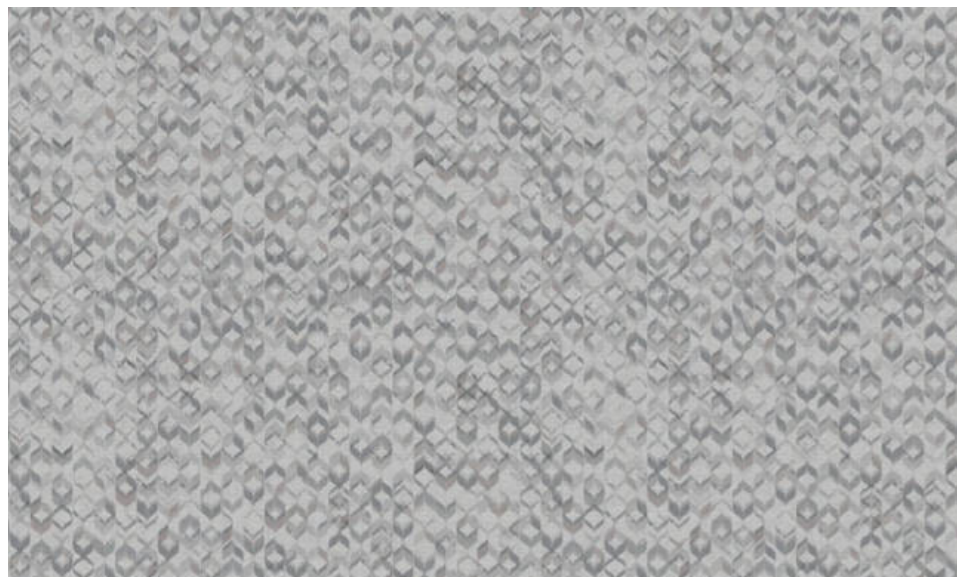

Codice/Code **WPT524**



Codice/Code **WPT517**



Codice/Code **WPT518**

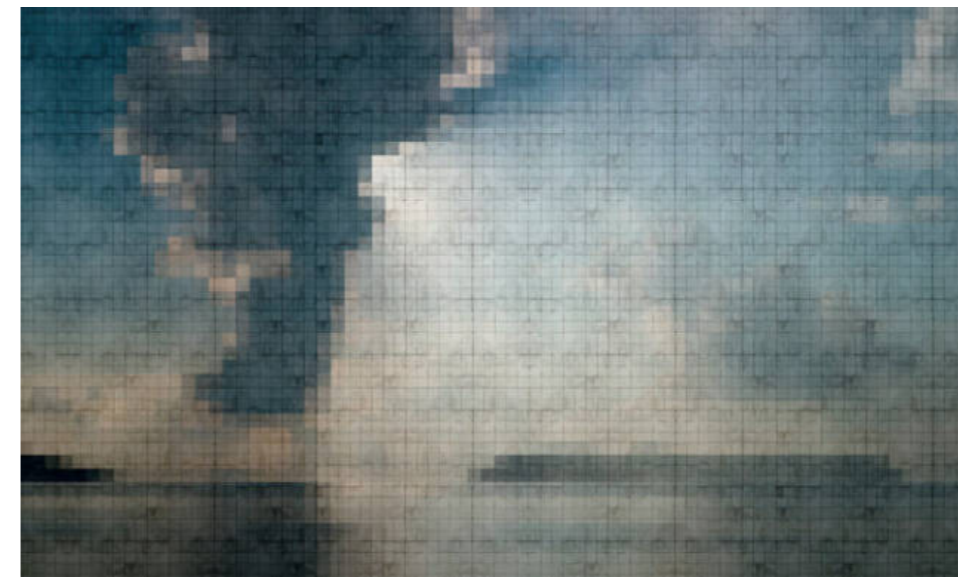

Codice/Code **WPT519**

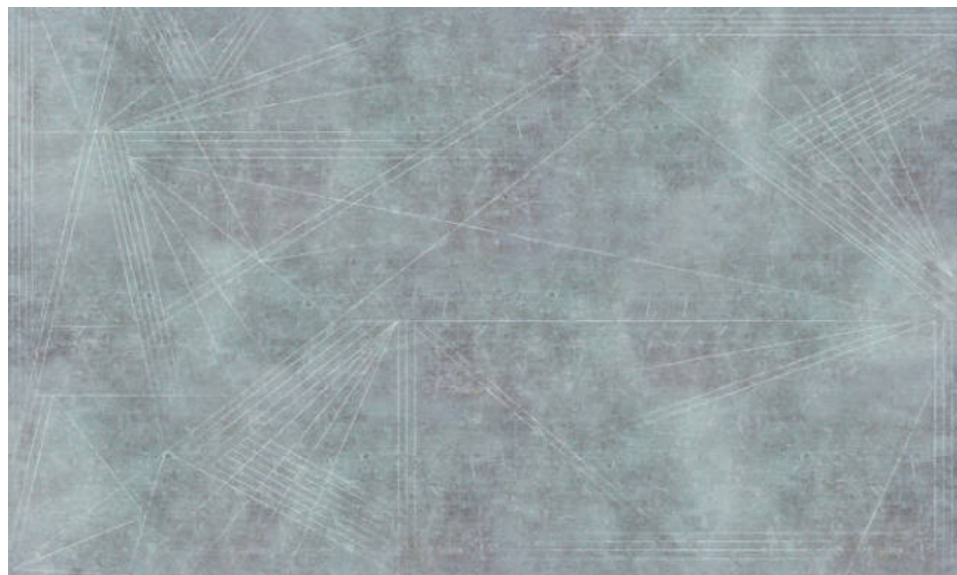

Codice/Code **WPT520**



Codice/Code **WPT527**

PAGE 79 - 184 - 277



Codice/Code **WPT522**

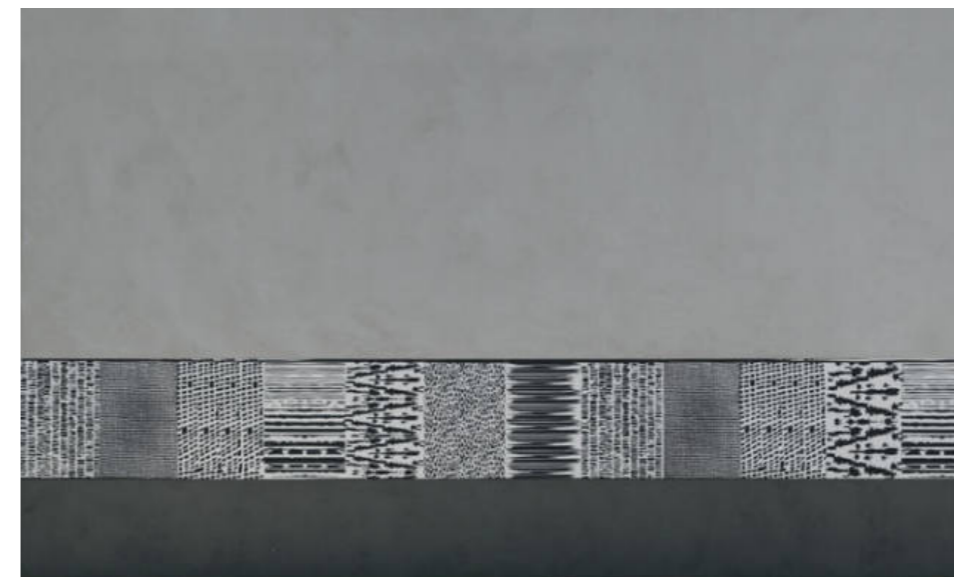

Codice/Code **WPT529**

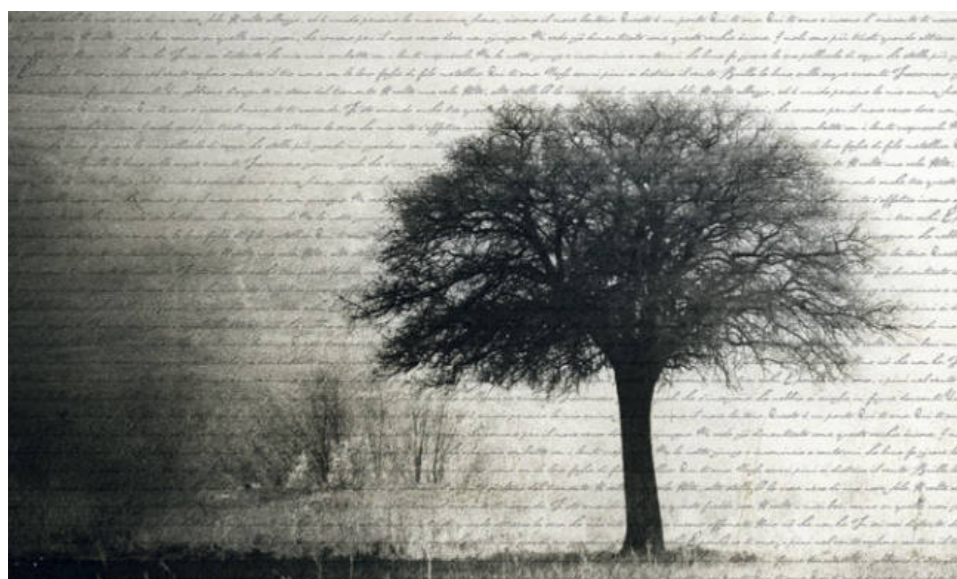

Codice/Code **WPT526**

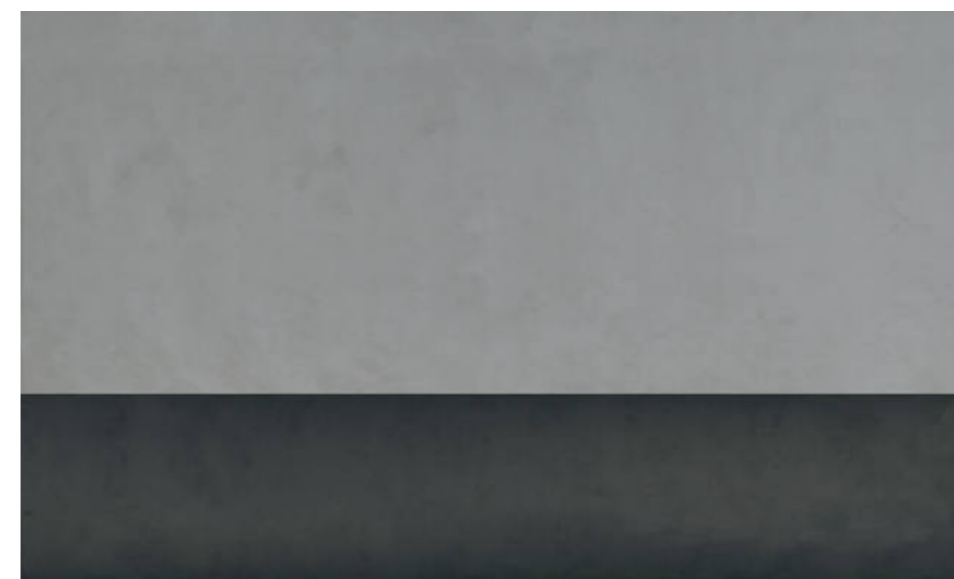

Codice/Code **WPT530**

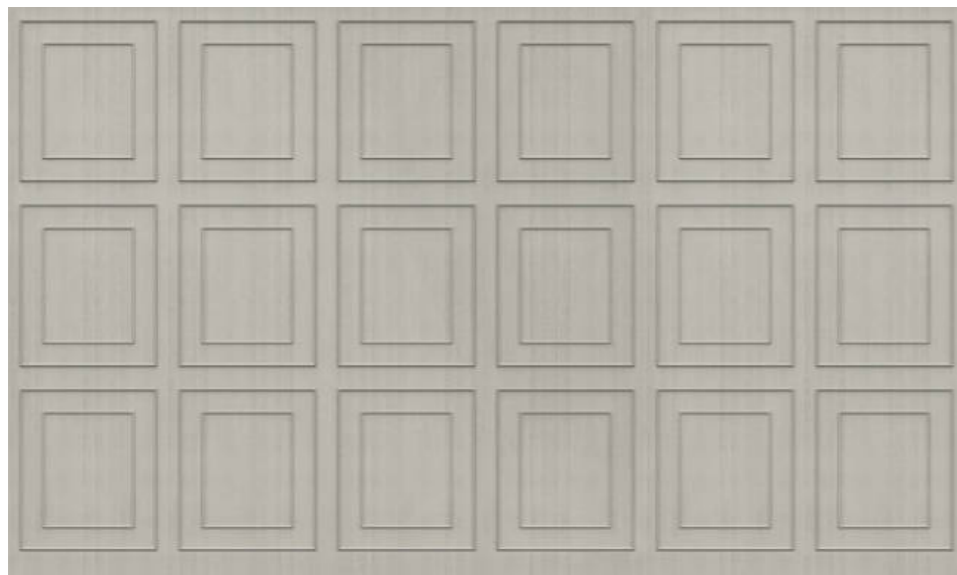

Codice/Code **WPT532**



Codice/Code **WPT533**

PAGE 68

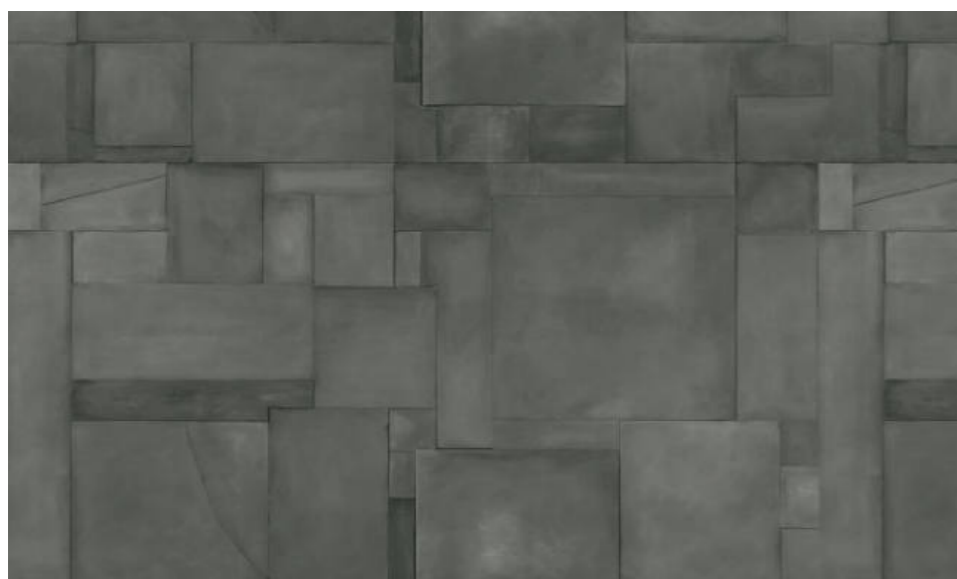

Codice/Code **WPT534**

PAGE 226



Codice/Code **WPT535**

PAGE 73 - 78 - 175



Wallpaper per vani a giorno PETALO / Wallpaper for PETALO open units only

Codice/Code **WPT536**

PAGE 270



Wallpaper per vani a giorno PETALO / PETALO open units only

Codice/Code **WPT537**

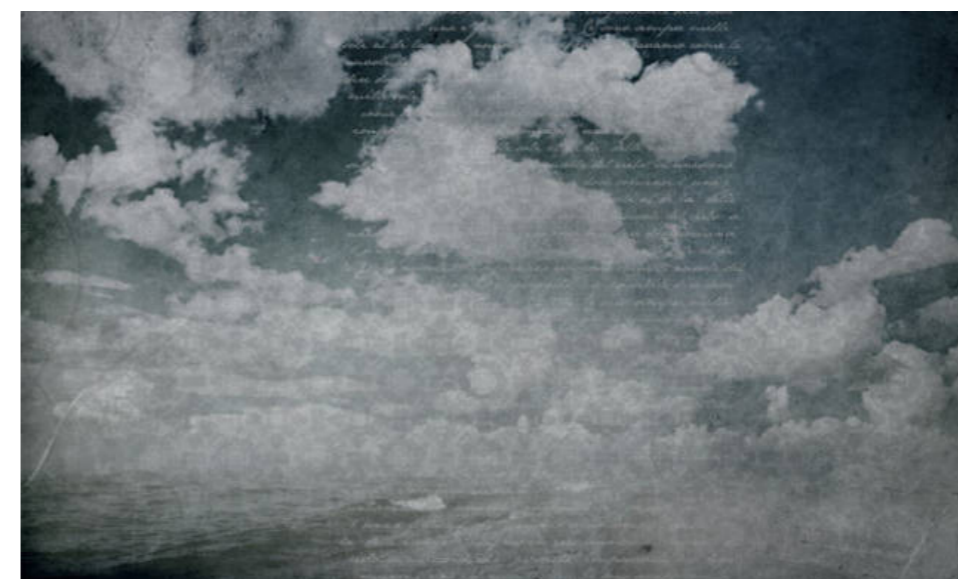

Codice/Code **WPT538**

Complementi technical pages

Decora la tua stanza con colore, materiali e grafiche: crea il tuo mood personale.
Decorate your room with our colours,

materials and graphic designs:
create your own, personal mood.

Ante, ante kaos, schienali e pensile z - Doors, kaos doors, back panels and z wall units

grafiche / graphic designs

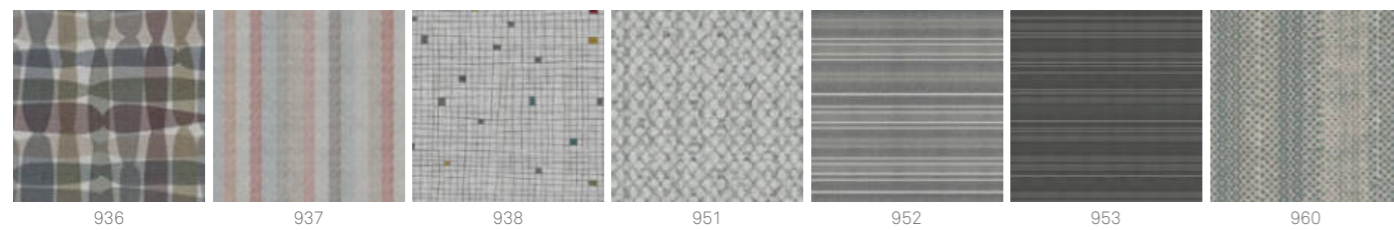
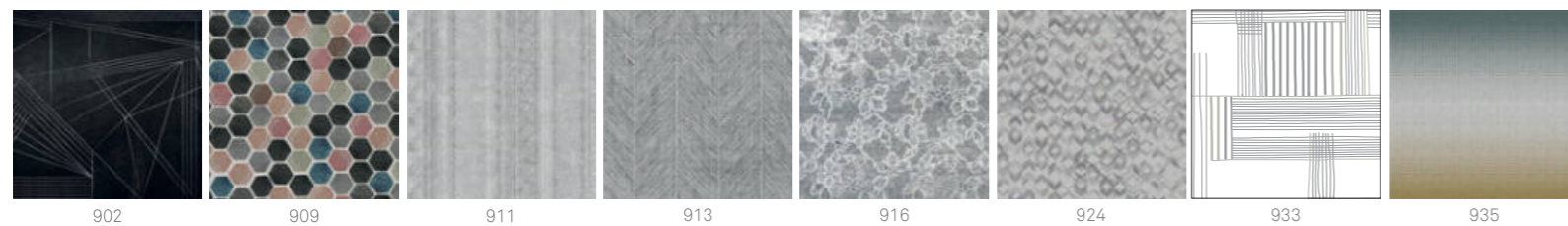

Boiserie krea e pannello fortebraccio - Krea back panels and fortebraccio panels

MATERICO ESSENZA / TEXTURED WOOD



MT-FO
Frassino Oriente
Eastern Ash



MT-RT
Rovere termocotto
Heat-treated Oak

MATERICO NODATO / TEXTURED KNOTTED



MT-RNC
Nodato chiaro
Light Knotted

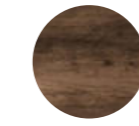

MT-RNS
Nodato scuro
Dark knotted

MATERICO OPACO / MATT TEXTURED

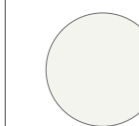

MT-OC BG
Bianco Gesso
Chalk white



MT-OC MP
Madreperla
Mother of pearl



MT-OC AN
Antracite
Anthracite

MATERICO PORO APERTO /
TEXTURED OPEN PORE



MT-PA BG
Bianco Gesso
Chalk white



MT-PA MP
Madreperla
Mother of pearl

MATERICO / TEXTURED



MT-CC
Cemento chiaro
Light cement



MT-CS
Cemento scuro
Dark cement

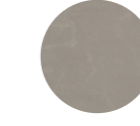

MT-CV
Cemento Cava
Cava cement



MT-MB
Maya Bronze



MT-INT S
Intreccio scuro



MT-INT C
Intreccio chiaro

LACCATI PORO APERTO / OPEN PORE LACQUERS



221 PA
Bianco Gesso
Chalk white



222 PA
Panna
Cream



224 PA
Madreperla
Mother of pearl



227 PA
Hot
Hot grey

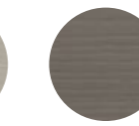

230 PA
Grigio Piacenza
Piacenza grey

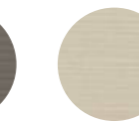

250 PA
Canapa
Hemp

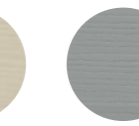

252 PA
Pomice
Pumice

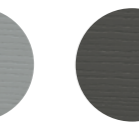

260 PA
Antracite
Anthracite

LACCATI / LAQUERED

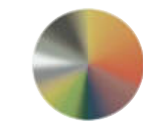

**colori laccati opachi
a campionario
(vedi pagina 333)**
choice of matt lacquer
colours from our range
(see page 333)

grafiche / graphic designs

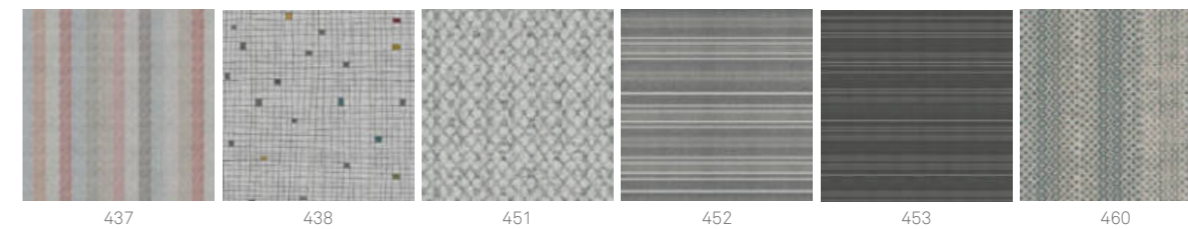
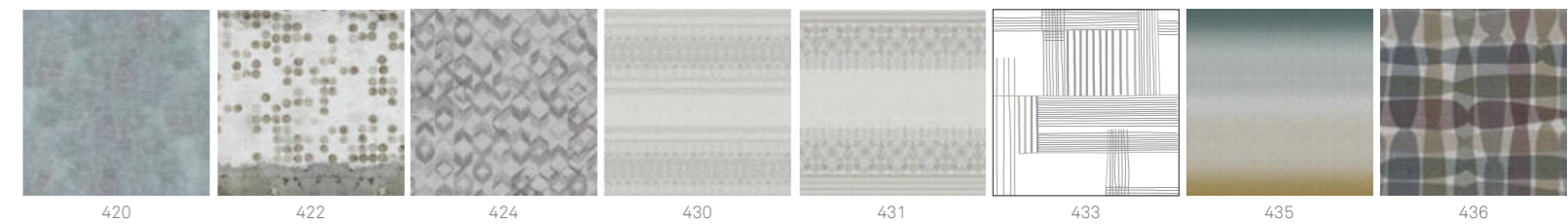
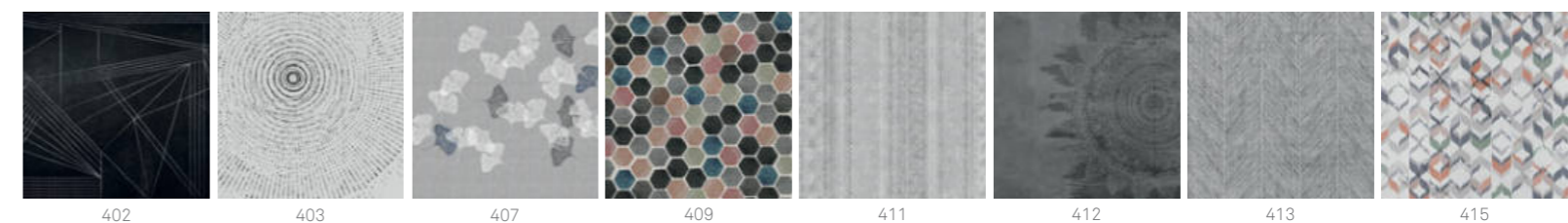

Essenze - Wood finishes

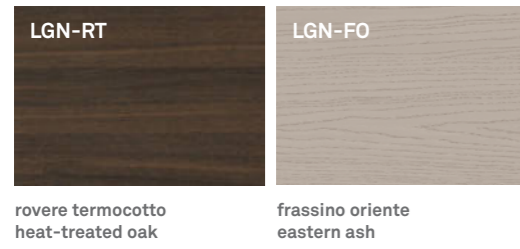

Tavolo Tudor - Tudor Table

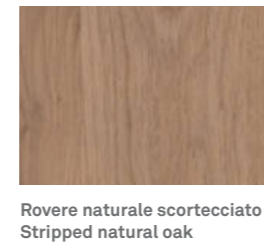

Materico essenza - Textured Wood

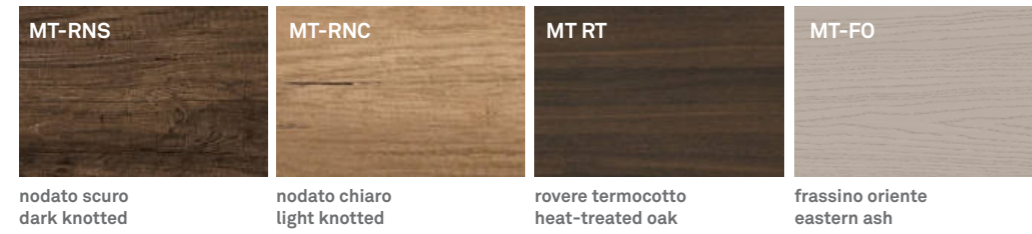

Materico - Textured



Materico opaco - Matt textured



Materico poro aperto - Open pore textured



HPL

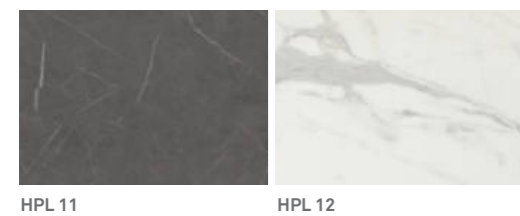

Laccati poro aperto - Open pore lacquers



Laccati opachi e lucidi - Matt and gloss lacquers



Le finiture e i colori sono indicativi e possono subire variazioni dovute alla tecnica di stampa. Finishes and colours are given as a rough guide only and are reproduced as accurately as the print process allows.

Finiture telaio ante vetro - Glass door frame finishes



telaio titanio
titanium frame

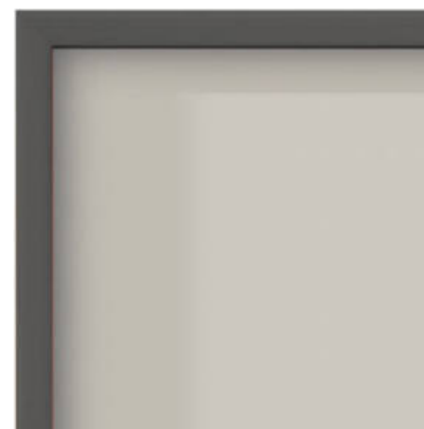

telaio colore*
coloured frame*

*In tutti i colori laccati della gamma Tomasella.

*In all the matt lacquer colours of the Tomasella range.

Vetri e specchi per anta telaio - Glass and mirror options for framed doors

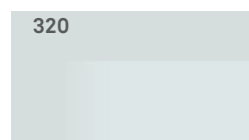

320
vetro trasparente
transparent glass

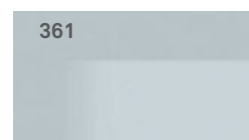

361
vetro satinato
satin glass

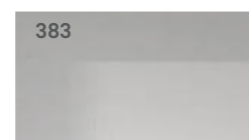

383
specchio grigio
grey mirror

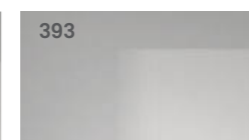

393
specchio grigio satinato
satin grey mirror

Vetri laccati lucidi per anta telaio - Gloss glass options for framed doors

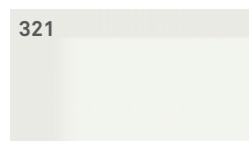

321
bianco gesso
chalk white

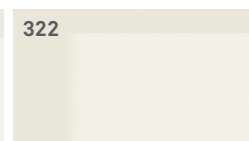

322
panna
cream

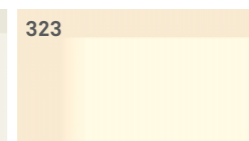

323
avorio
ivory

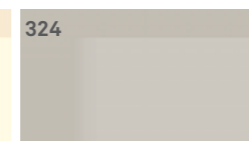

324
madreperla
mother of pearl

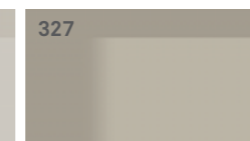

327
hot
hot grey

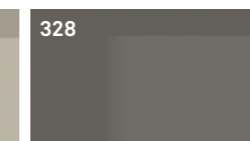

328
smoke
smoke



330
grigio piacenza
piacenza grey



331
nero fumo
smoke black



334
rosso
red

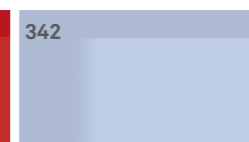

342
celesti
light blue



345
pink
pink



347
oliva
olive



348
arancio
orange

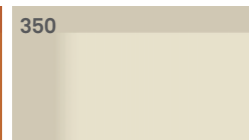

350
canapa
hemp

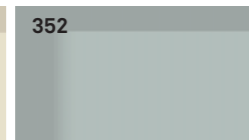

352
pomice
pumice

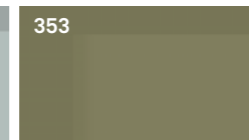

353
verde muschio
moss green

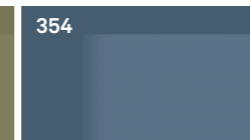

354
blu avio
air force blue

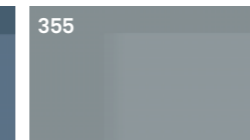

355
carta da zucchero
blue grey



356
bordeaux
burgundy



357
pesca
peach



358
zafferano
saffron

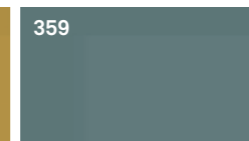

359
salvia
sage

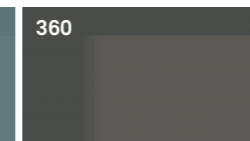

360
antracite
anthracite

Finiture ante Metropolis - Metropolis door finishes



Elegante e lineare, l'anta Metropolis è disponibile con telaio in finitura antracite abbinata al vetro fumè o trasparente. Lo spessore verticale diventa presa maniglia per un'apertura pratica e bella. L'anta Metropolis è perfetta per composizioni spalla.

Elegant and linear, the Metropolis door is available with an anthracite finish frame paired with smoked or transparent glass. The vertical profile becomes a beautiful and practical grip edge. The Metropolis door pairs perfectly with open shelving units.

Vetri per anta Metropolis - Metropolis door glass options

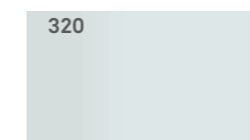

320
vetro trasparente
transparent glass

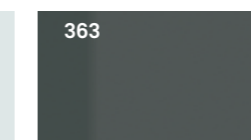

363
vetro fumè
smoked glass

pagine di sintesi

testi in spagnolo,
francese e tedesco

Páginas de síntesis

Descriptifs

Seitenübersicht

Textos en español, francés y alemán
Textes en espagnol, français et allemand
Texte in spanisch, französisch und deutsch

E' vietata ogni riproduzione totale e parziale in Italia e all'estero.

Reproduction of all or any part of this publication in Italy or in any other country is prohibited.



product design
ROSSI & CO.
art direction and styling
ROSSI & CO.
graphic design
ROSSI & CO.
photography
STUDIO INDOOR
color separation
Z13
print
OGM



TOMASELLA.IT

